

WM Series

Wormgear Units
Imperial Gearing Centres

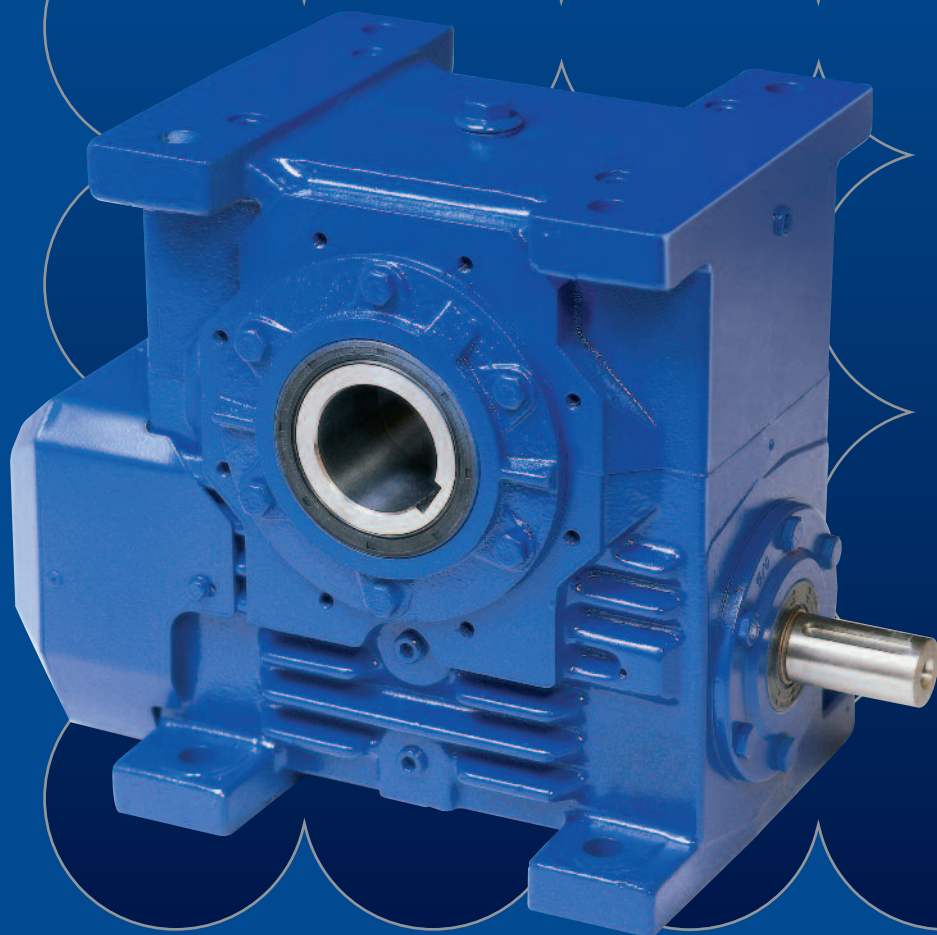

RENOLD
Superior Gear Technology

www.renold.com

WM Series - Product Features

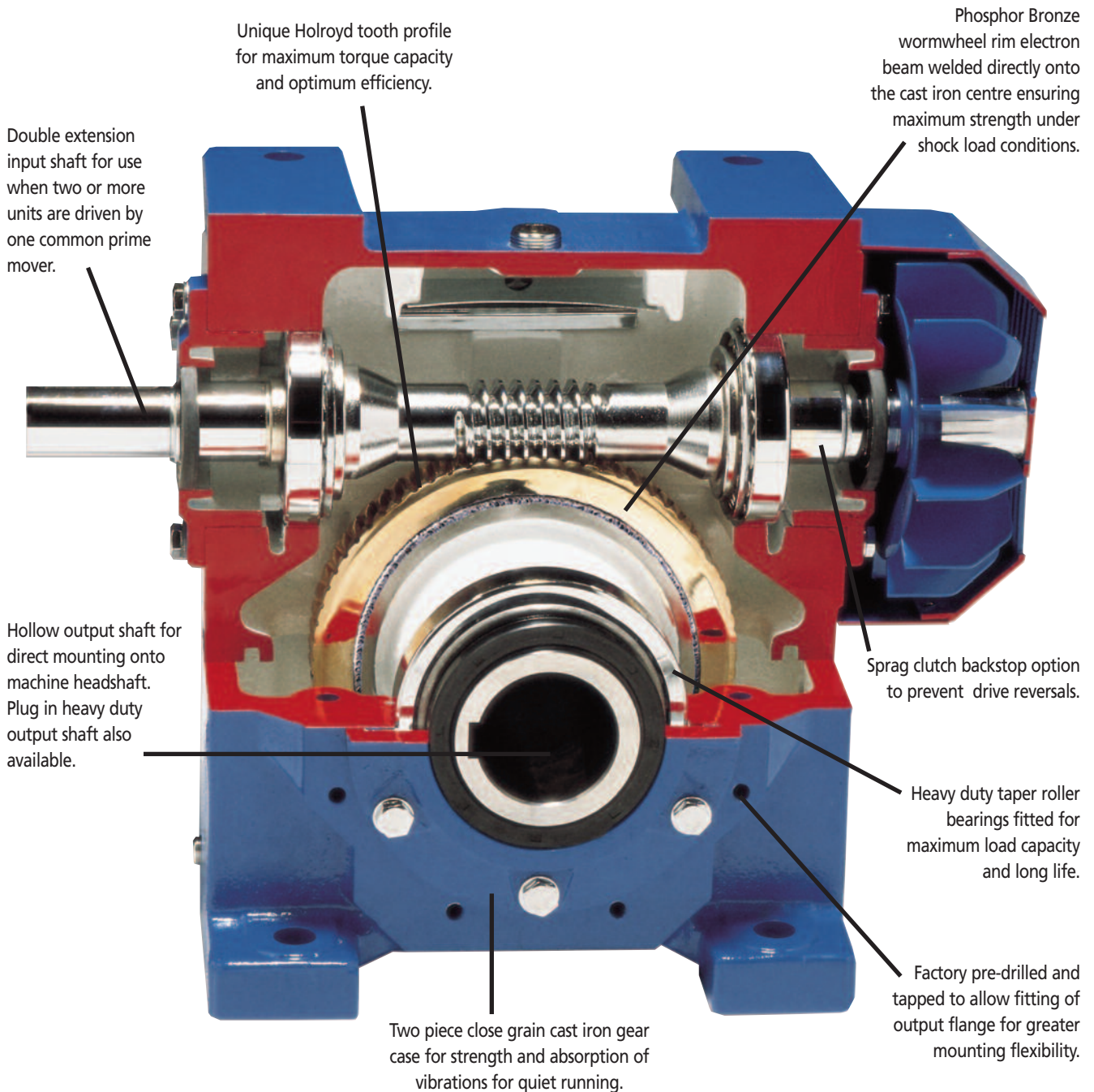

The WM Series range of products has been designed and built to a modular form to allow the combination of other Renold products to extend the torque, ratio and speed range. Each unit is designed for use with IEC and NEMA electric motors, with B5 and B14 flanges.

Applications:

- Conveyors
- Mining
- Timber
- Textiles
- Materials Handling
- Packaging Machinery
- Food Process Machinery
- Water Treatment
- Foundry Equipment



Section of electron beam welded wormwheel rim and centre showing the fusion of the bronze wormwheel rim onto the cast iron centre. This high security fit allows transmission of power under shock load conditions.

Contents

	Page No
WM Series Unit Features	2
ATEX Approval	4
General Specification	5
Product Design Variations	6 - 7
Unit Mounting and Handling Details	8 - 9
Electric Motor Specifications	10 - 11
Ordering Designation Code	12
Selection of WM Series units	13 - 14
Load Classification by Application	15
Overhung and Thrust Load Capacities	16 - 18
Exact Ratios	19
Selection Data - Single Reduction Units	20 - 33
Dimensions - Single Reduction Units	34 - 38
Dimensions - Single Reduction Units Motorised	39
Dimensions - Output Shaft Shrink Disc	40
Dimensions - Output Shafts	41
Dimensions - Torque Arm	42
Installation, Maintenance and Storage	43
Lubrication	44
Renold Worldwide Sales and Service	46 - 47

ATEX Approval Details

ATEX Approval

RENOLD Gears products for operating in potentially explosive atmospheres.

General

- **RENOLD** Gears units are classified as ATEX Group II Category 2 equipment, which embodies sufficient safeguards to be suitable for use in potentially explosive atmospheres for normal operation and for operation during an expected malfunction.
- It is essential that there is sufficient lubricant to prevent the gears and bearings running 'dry'. Gear units should be inspected daily for signs of oil leakage, overheating or noisy operation.
- Gear units should be cleaned at regular intervals depending on the operating conditions, to ensure that dust coatings never exceed 5mm. Plastic parts should be wiped clean with a damp cloth.
- Oil leaks should be dealt with as quickly as practical. Compound joint faces and shims should be cleaned and thread-locking sealant should be applied to bolts and plugs prior to re-assembly.

- The temperature of any external surfaces must not exceed the permitted maximum of 135°C (T4).
- Higher temperature class T3 is available dependant on unit mounting, ratio and gear type. For further details consult Renold.
- As a general rule, gear units should be mounted with their feet horizontal. For other mountings, particularly with shaft mounted units, consult **RENOLD** Gears.

WARNING: IF MOUNTING WITH VERTICAL INPUT OR OUTPUT SHAFTS, THE ATEX CERTIFICATION DOES NOT APPLY.

Unit Selection

- The gear unit selection procedures must include an additional reliability factor of 1.25 for mechanical ratings and 1.25 for thermal ratings.

ATEX Nameplate

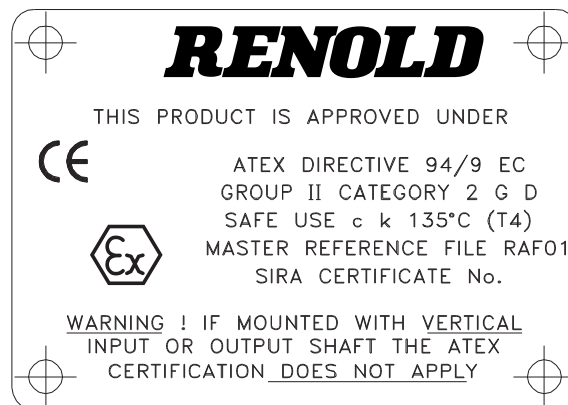

WM Series - Product Specification

Gear Case

The gear cases are of close grained cast iron with all joints and bearing bores accurately machined to ensure oil tightness and precise gear location.

Wormshaft and Wormwheel

The worm is integral with its shaft and manufactured from alloy steel, casehardened on the threads and ground and polished on the thread profiles.

The wormwheel rim is made from bronze complying with BS 1400 PB2-C (centrifugally cast) and secured to the cast iron centre by the electron beam welding process.

The Holroyd gear form used in the WM Series gear units corresponds to British Standard recommendations but, in addition, has an exclusive feature which consists principally of an important modification to the worm threads and wheel teeth which confer additional valuable properties to gear performance. This ensures that our gears will run correctly and transmit true uniform angular velocity when running under all load conditions. The modification also gives a tapered oil entry gap between the teeth, which drags the lubricant between the surfaces and results in more efficient lubrication. Standard worm gears have right-hand threads but left-hand threads can be made to order.

Shafts

Standard shaft extensions are to metric dimensions, but imperial shaft extensions for units complying with BS3027: 1968 or to suit the requirements of the North American market are also available. The output shaft is manufactured in carbon steel, but if required by applicational conditions, can be made from high tensile steel, in single or double extension.

WM Series unit sizes 4" to 8" are supplied as hollow output shaft type as standard and all output shafts are plug-in design, single and double extension.

The Agitator version WMA however uses a solid output shaft construction for maximum strength, particularly when used on mixer applications. The WM 9 Series units are supplied with solid construction output shaft throughout the range of design types. All input shafts in the WM Series range are standard double extension and are metric dimensions at one end and American standard - inch at the other.

Unless otherwise requested, the metric extension will be the exposed input extension except for those supplied to North America and Canada.

Preferred Ratios

Certain gear ratios have been nominated as preferred ratios and are shown in red on pages 28 to 41. This has been done with a view to providing a competitive lead time.

Bearings

Standard metric taper/roller bearings are fitted throughout the WM Series range of units in both single and double extension shaft options.

Oil Seals

Semi-dual lip oil seals are fitted to all hollow output shaft units and single lip seals are fitted to the input shaft of all unit sizes and the output of WM9 unit range and all agitator unit types.

Dry Well Feature

The WM Series unit sizes 4" to 8" can be factory fitted with a 'dry-well' adaption at the output shaft to create a non oil leak unit. The output shaft bearing within the dry well is grease lubricated.

The non leak feature is particularly important on mixer drive applications in food and chemical plants where the unit shaft is vertically down.

Lubrication

Gear and bearings are positively lubricated by oil from the sump in the underdriven and overdriven versions at normal motor speeds. With the vertical and agitator types, grease lubrication is necessary to the wheel line bearings.

For lower speeds it may be necessary to consider grease lubrication of certain bearings and in this instance it is advisable to consult with Renolds Engineers. Full lubrication details can be found under the "Installation & Maintenance" section.

Cooling

Maximum heat dissipation by air cooling is carried out by radial fan directing air over ribbed gear case. Where applicational circumstances permit, standard units can be supplied without a fan.

Backstop

Sprag clutch backstops can be fitted to most units to prevent unit run back when required.

Double Reduction Units

Two stage, double reduction gear units are available with ratios from 75:1 to 4900:1.

WM Series - Product Design Variations

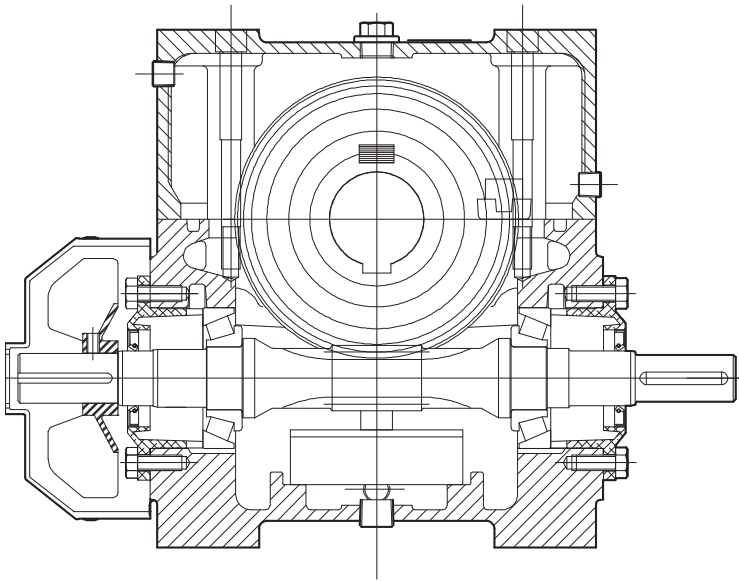

Hollow output shaft unit showing standard metric extension input shaft and American extension at the fan end.

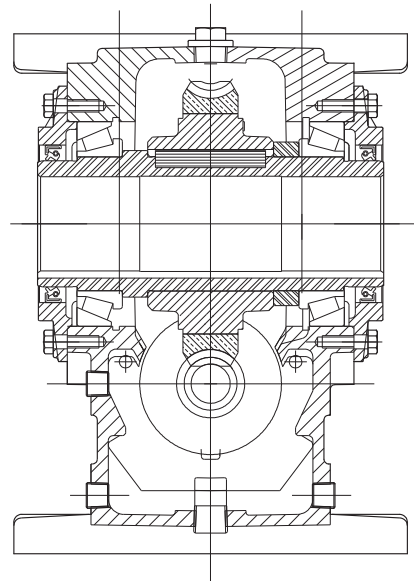

Standard hollow output shaft with semi dual lip oil seal for added oil retention.

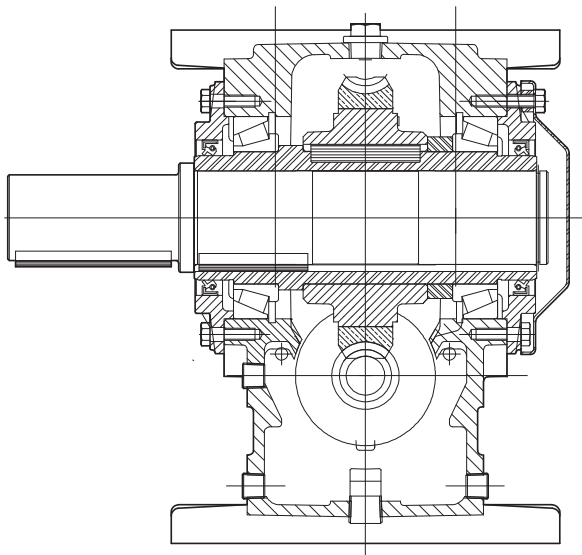

Underdriven unit with standard plug-in output shaft. Single and double extension shafts are available with metric American dimensions.

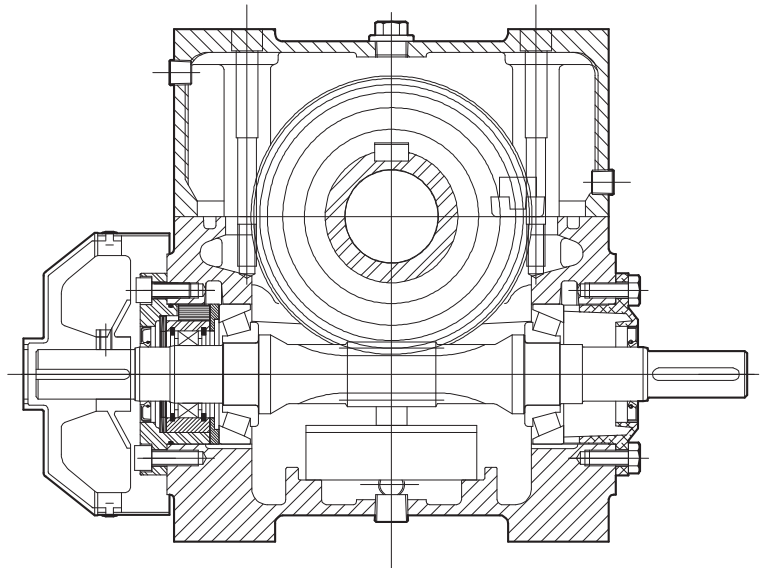

Sprag Clutch, anti run-back assembly fitted to the fan extension end of the input shaft, to prevent unit run back. The Sprag Clutch can be supplied as a kit for retro fitting at any time.

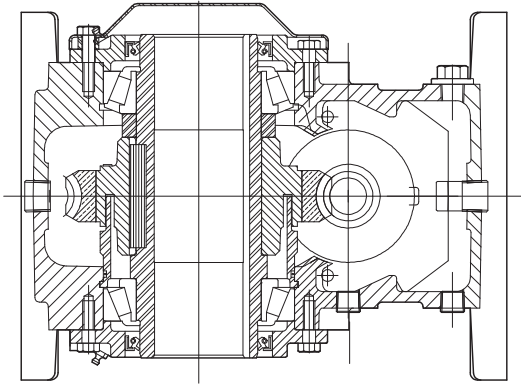
WM Series - Product Design Variations

Dry well adaption fitted at the output of the WM Series unit. The non leak feature is particularly important on mixer applications in the food and chemical industry.

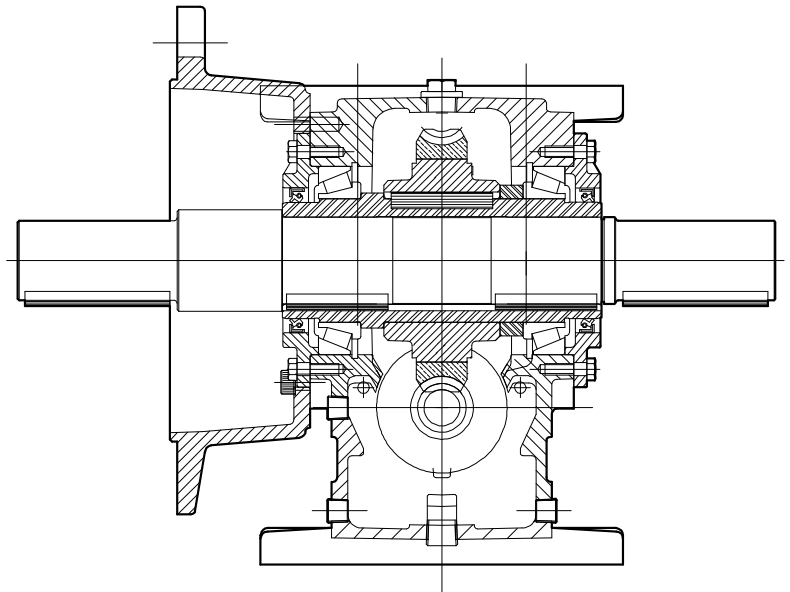

Unit fitted with output location flange and double extension output shaft, one standard extension and one longer than standard compensating for the flange.

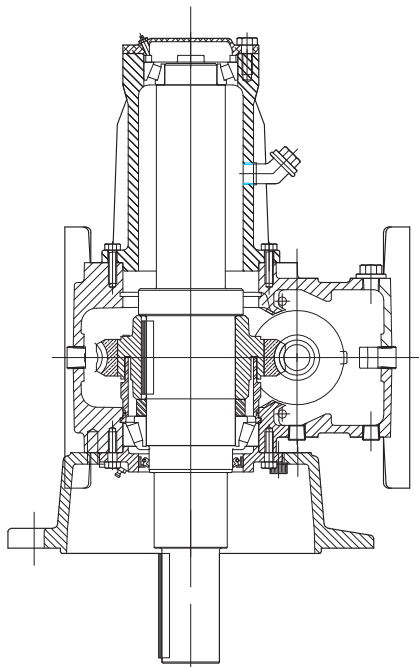

WMA - Agitator unit with output shaft down. The unit is shown with the dry well feature. The output shaft bearings have a greater bearing span to allow for higher external loads imposed by mixer and agitator blades.

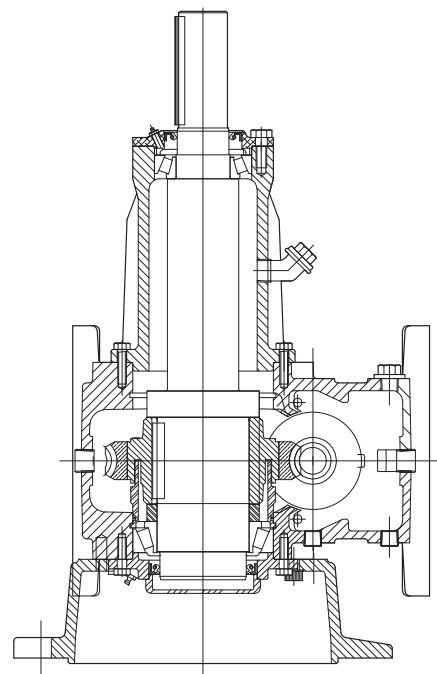

Agitator unit with output shaft up, particularly suited for cooling fan drives.

WM Series - Single Reduction - Mounting & Handling

WMU - Underdriven WMSM - Shaft Mounted

No Sprag backstop fitted.
Sprag backstop fitted.

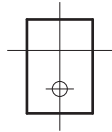

UA
UB

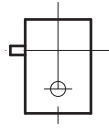

UC
UD

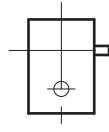

UE
UF

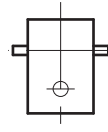

UG
UH

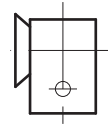

UJ
UK

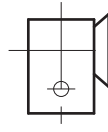

UL
UM

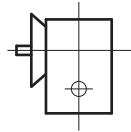

UN
UP

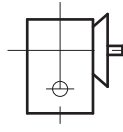

UQ
UR

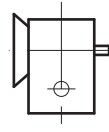

US
UT

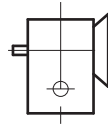

UU
UV

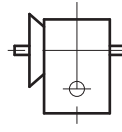

UW
UX

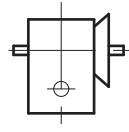

UY
UZ

WMO - Overdriven

No Sprag backstop fitted.
Sprag backstop fitted.

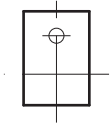

OA
OB

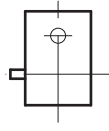

OC
OD

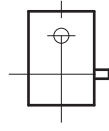

OE
OF

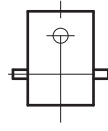

OG
OH

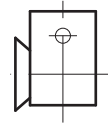

OJ
OK

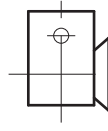

OL
OM

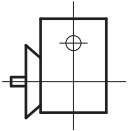

ON
OP

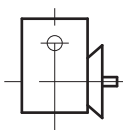

OQ
OR

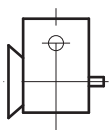

OS
OT

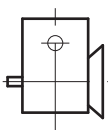

OU
OV

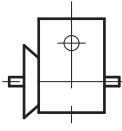

OW
OX

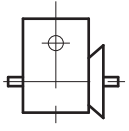

OY
OZ

WMU - WMO Suitable For Wall Mounting

No Sprag backstop fitted.
Sprag backstop fitted.

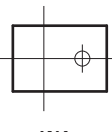

WA
WB

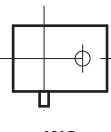

WC
WD

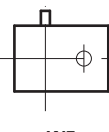

WE
WF

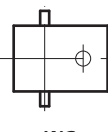

WG
WH

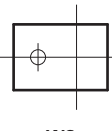

WS
WT

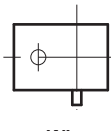

WL
WM

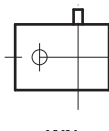

WN
WP

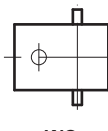

WQ
WR

WM Series - Single Reduction - Mounting & Handling

WMV - Vertical

No Sprag backstop fitted.
Sprag backstop fitted.

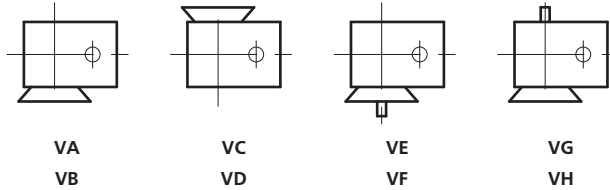

No Sprag backstop fitted.
Sprag backstop fitted.

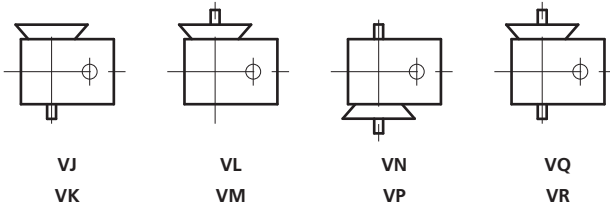

No Sprag backstop fitted.
Sprag backstop fitted.

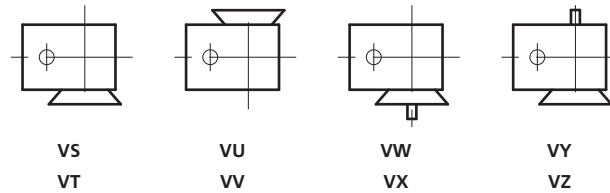

No Sprag backstop fitted.
Sprag backstop fitted.

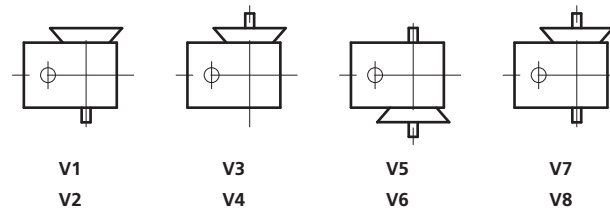

WMA - Agitator

No Sprag backstop fitted.
Sprag backstop fitted.

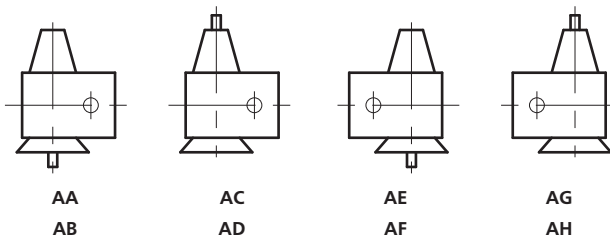

Electric Motor Specification

DM1 : 4 POLE/1500rpm

DM1 = cast iron series 1 MOTOR SIZE acc. to IEC-DIN	Rated Output Power P_N $K_W W$	Full-load Current			Full-load Speed n_N min^{-1}	Full-load power factor $\cos \varphi$	Full-load efficiency η %	Locked rotor current L_a / L_N	Locked rotor torque M_a / M_N	Break down torque M_k / M_N	Moment of inertia J kgm^2	nett weight IM B3 m kg
		380 V L_U A	400 V L_N A	420 V L_O A								
DM1 90 S4	1.1	2.80	2.70	2.80	1390	0.78	74.5	5.7	2.4	2.7	0.0021	22
DM1 90 L4	1.5	3.60	3.60	3.70	1410	0.77	78.7	5.7	2.9	3.2	0.0027	28
DM1 100 L4	2.2	4.90	4.90	5.0	1425	0.81	80.0	6.3	2.9	3.1	0.0054	34
DM1 100 LX4	3.0	6.40	6.40	6.50	1425	0.83	81.8	6.7	2.8	3.9	0.0067	38
DM1 112 M4	4.0	8.70	8.40	8.30	1445	0.85	83.8	6.7	2.1	2.9	0.0086	44
DM1 132 S4	5.5	10.70	11.1	10.8	1450	0.83	85.1	7.5	2.4	3.0	0.0205	61
DM1 132 M4	7.5	15.10	14.5	14.4	1450	0.86	87.5	7.3	2.7	3.3	0.0296	73
DM1 160 M4	11	22.10	21.2	21.3	1450	0.85	88.1	7.6	2.5	3.0	0.0724	113
DM1 160 L4	15	27.60	28.1	28.2	1460	0.86	89.5	7.9	2.7	3.1	0.0929	133
DM1 180 M4	18.5	35.30	33.4	33.4	1470	0.88	90.9	7.5	2.5	3.0	0.1350	167
DM1 180 L4	22	42.00	39.8	39.5	1465	0.88	90.9	7.5	2.2	3.1	0.1360	181
DM1 200 L4	30	55.60	53.3	52.0	1480	0.88	92.0	7.2	2.5	3.2	0.2450	232
DM1 225 S4	37	68.20	65.5	64.0	1485	0.88	92.3	7.3	2.0	2.8	0.3900	287
DM1 225 M4	45	81.30	79.1	76.0	1480	0.89	92.4	7.5	2.2	3.0	0.4500	322
DM1 250 M4	55	101	96.0	95.0	1480	0.89	93.0	7.0	2.3	3.1	0.6400	381
DM1 280 S4	75	137	131	126	1480	0.88	93.5	6.1	2.0	2.9	1.0450	510
DM1 280 M4	90	168	152	155	1485	0.88	94.2	7.8	2.7	3.3	1.3960	600

DM1 : 6 POLE/1000rpm

DM1 90 S6	0.75	2.30	2.18	2.10	920	0.72	69.0	3.6	2.3	2.3	0.0029	23
DM1 90 L6	1.1	3.00	3.10	3.20	930	0.71	72.6	4.4	2.1	2.9	0.0035	25
DM1 100 L6	1.5	3.90	4.00	4.20	930	0.73	73.5	4.7	2.4	2.9	0.0069	33
DM1 112 M6	2.2	5.10	5.10	5.10	940	0.79	78.8	5.2	1.6	2.4	0.0129	39
DM1 132 S6	3.0	6.80	7.00	7.40	970	0.75	81.0	6.4	1.5	2.0	0.0274	56
DM1 132 M6	4.0	9.20	9.40	9.90	975	0.71	82.0	6.8	2.1	3.1	0.0343	71
DM1 132 MX6	5.5	11.9	12.0	12.4	975	0.77	85.5	7.5	2.0	4.0	0.0431	75
DM1 160 M6	7.5	16.1	15.9	16.0	965	0.79	85.3	6.5	1.8	3.0	0.0800	108
DM1 160 L6	11	22.7	22.4	22.6	970	0.80	87.8	7.1	1.8	3.1	0.1080	131
DM1 180 L6	15	29.5	29.3	29.1	980	0.83	89.2	7.2	2.5	2.9	0.1670	171
DM1 200 L6	18.5	36.5	35.5	35.1	980	0.84	89.9	6.7	2.0	3.0	0.3020	216
DM1 200 LX6	22	42.3	40.6	39.8	975	0.87	89.8	6.7	2.0	2.8	0.3420	225
DM1 225 M6	30	57.6	55.4	54.2	985	0.85	91.7	6.2	2.3	2.8	0.5250	292
DM1 250 M6	37	69.5	67.3	65.7	985	0.87	91.5	6.8	2.1	3.1	0.8070	408
DM1 280 S6	45	79.1	80.2	77.3	985	0.88	92.4	6.5	2.0	2.9	1.3340	465
DM1 280 M6	55	97.6	99.0	95.4	985	0.87	92.7	6.7	2.1	3.0	1.5980	540

Electric Motor Dimensions

DM1 : 4 POLE/1500rpm

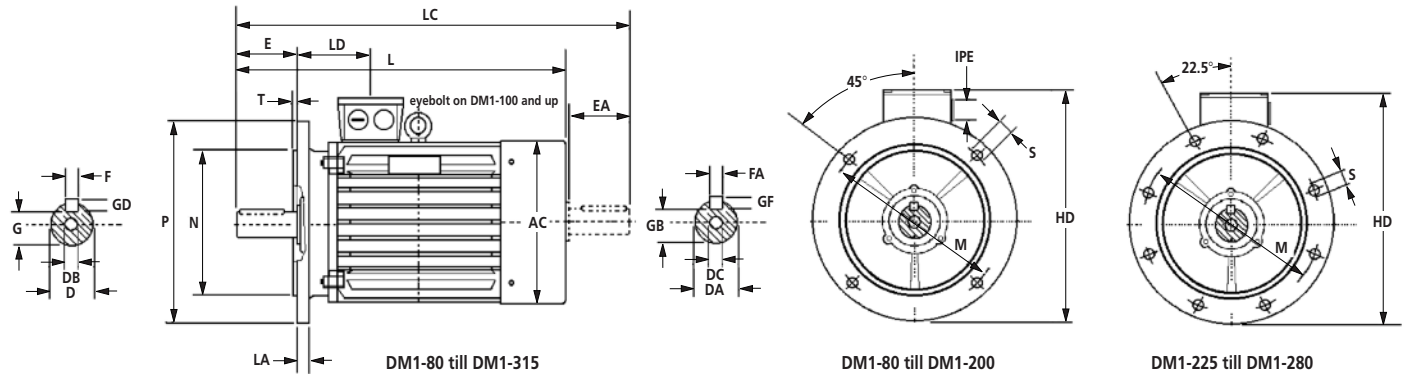

Type	Poles	AC	D	E	EA	HD	L	LC	LD	M	N	P	S	T	IPE	Flange
DM1 80	2/4/6/8	154	19	40	40	245	295	338	75	165	130j6	200	4012	3.5	2xPg16	FF165
DM1 90S	2/4/6/8	174	24	50	50	225	315	368	78	165	130j6	200	4012	3.5	2xPg16	FF165
DM1 90L	2/4/6/8	174	24	50	50	225	340	393	83	165	130j6	200	4012	3.5	2xPg16	FF165
DM1 100L/LX	2/4/6/8	195	28	60	60	305	375	438	83	215	180j6	250	4015	4	2xPg16	FF215
DM1 112M	2/4/6/8	217	28	60	60	315	400	463	84	215	180j6	250	4015	4	2xPg21	FF215
DM1 132S/SX	2/4/6/8	256	38	80	80	360	465	553	100	265	230j6	300	4015	4	2xPg21	FF265
DM1 132M	2/4/6/8	256	38	80	80	360	510	593	100	265	230j6	300	4015	4	2xPg21	FF265
DM1 160M/MX	2/4/6/8	311	42	110	110	505	615	728	150	300	250j6	350	4019	5	2xPg29	FF300
DM1 160L	2/4/6/8	311	42	110	110	505	670	783	150	300	250j6	350	4019	5	2xPg29	FF300
DM1 180M	2/4/6/8	352	48	110	110	530	700	813	160	300	250j6	350	4019	5	2xPg29	FF300
DM1 180L	2/4/6/8	352	48	110	110	530	740	853	160	300	250j6	350	4019	5	2xPg29	FF300
DM1 200L/LX	2/4/6/8	394	55	110	110	580	770	883	190	350	300h6	400	4019	5	2xPg36	FF350
DM1 225S	4/8	442	60	140	110	640	815	928	190	400	350h6	450	8019	5	2xPg36	FF400
DM1 225M	2	442	55	110	110	640	820	933	190	400	350h6	450	8019	5	2xPg36	FF400
DM1 225M	4/6/8	442	60	140	110	640	845	958	190	400	350h6	450	8019	5	2xPg36	FF400
DM1 250M	2	481	60	140	110	695	910	1028	203	500	450h6	550	8019	5	2xPg42	FF500
DM1 250M	4/6/8	481	65	140	110	695	910	1028	203	500	450h6	550	8019	5	2xPg42	FF500
DM1 280S	2	543	65	140	110	770	995	1108	220	500	450h6	550	8019	5	2xPg42	FF500
DM1 280S	4/6/8	543	75	140	140	770	995	1138	220	500	450h6	550	8019	5	2xPg42	FF500
DM1 280M	2	543	65	140	110	770	1045	1158	220	500	450h6	550	8019	5	2xPg42	FF500
DM1 280M	4/6/8	543	75	140	140	770	1045	1188	220	500	450h6	550	8019	5	2xPg42	FF500

Type	IPE	X	Y	Z
DM1 80	2xPg 16	102	104	58
DM1 90 S	2xPg 16	102	104	58
DM1 90 L	2xPg 16	102	104	58
DM1 100 L/LX	2xPg 16	102	104	58
DM1 112 M	2xPg 21	108	123	68
DM1 132 S/SX	2xPg 21	108	123	68
DM1 132 M	2xPg 21	108	123	68
DM1 160 M/MX	2xPg 29	150	160	80
DM1 160 L	2xPg 29	150	160	80
DM1 180 M	2xPg 29	150	160	80
DM1 180 L	2xPg 29	150	160	80
DM1 200 L	2xPg 36	188	208	97
DM1 225 S	2xPg 36	188	208	97
DM1 225 S	2xPg 36	188	208	97
DM1 225 M	2xPg 36	188	208	97
DM1 225 M	2xPg 36	188	208	97
DM1 250 M	2xPg 42	216	246	112
DM1 250 M	2xPg 42	216	246	112
DM1 280 S	2xPg 42	216	246	112
DM1 280 S	2xPg 42	216	246	112
DM1 280 M	2xPg 42	216	246	112
DM1 280 M	2xPg 42	216	246	112

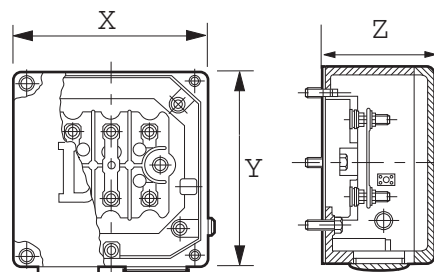

Ordering Procedure - Unit Designation Code

To ensure that the correct 'WM' Series unit is supplied and that your order is processed without delay, please quote the full designation code as detailed below:

Unit Designation Code - Speed Reducer Unit

1	2	3	4	5
WM	4	10	UA	M

- 1** Unit type - WM Series speed reducer unit
- 2** Unit size - 4, 5, 6 etc.
- 3** Unit nominal ratio - 5:1, 10:1, 30:1 etc
- 4** Unit mounting and assembly see pages 8 - 9
- 5** Unit shaft/bore details M - Metric A - American

Unit Designation Code - Motorised Unit

1	2	3	4	5	6	7	8
MWM	4	10	WA	5.5	4	132	M

- 1** Unit type - WM Series motorised
- 2** Unit size - 4, 5, 6 etc.
- 3** Unit nominal ratio - 5:1, 10:1, 30:1 etc
- 4** Unit mounting assembly. see page 8 - 9
- 5** Motor power (KW)
- 6** Motor speed in poles - 4, 6 etc.
- 7** Motor IEC frame sizes see page
- 8** Unit shaft/bore details M - Metric A - American

If a sprag clutch holdback is fitted into the unit, the shaft direction of rotation should be indicated at order stage.

WM Series - Selection Information

To select a worm gear unit the following basic information must be known and, if we are to make the selection, should be submitted in full to our Technical Sales Department.

Power

- a) Prime mover, type and output power (kW).
- b) Gear unit input and output power required (kW).
- c) For input speeds below 250 rev/min consult our Technical Sales Department giving details of required output torque (Nm) and diameter of driven shaft (mm).

Speed

Gear unit input and output rev/min.

Duty

- a) The characteristics of the drive eg. degree of impulsiveness of the driven load.
 - b) Duration of service in hours/day.
 - c) Starting load (kW) and number of starts per day.
 - d) For intermittent duty, reversing or shock loading, state normal power (kW) and frequency.
 - e) Disposition and details of external loads imposed on input/output shafts.
 - f) Working conditions, i.e. clean, dusty, moist, abnormal temperatures etc.
- If the operating conditions are in any way unusual it is advisable to consult our Technical Sales Department.

Enquiry/Ordering Procedure

At the order or enquiry stage, please quote the catalogue reference, shaft assembly number and nominal ratio or exact ratio if this important (see tables). Non standard mounting positions should be indicated with a sketch. Where a double extension wormwheel shaft is required, please state any special requirements regarding alignment of keyways.

Mechanical Rating

The mechanical powers listed are those which the WM Series units will transmit for 10 hours each day and correspond to a service factor of 1.0. Where non-uniform loading or a working day other than 10 hours is involved, a service factor f_D should be applied to the selection power or torque which is taken from table 2. High numbers of

starts per hour also influence the mechanical selection. Table 3 shows the starts factor f_s which should also be applied to the selection power or torque.

For guidance a comprehensive list of the various load conditions for a number of applications is given in Table 1. When confirming the mechanical selection powers therefore, the rating must be equal to or greater than calculated power or torque demand x application service factor f_D (table 1 and table 2) x starts factor f_s (table 3)

Efficiencies

The efficiency figures are approximate only and are those that could be expected from a gearbox which is fully run-in and operating under full load with the lubricant at its full working temperature.

For intermittent rating where the lubricant may remain comparatively cool, the efficiency may be somewhat lower due to the increased oil churning losses associated with the higher viscosity of the cool oil. We shall be pleased to advise on any particular application.

Thermal Rating

The thermal ratings given are those which the gear units will transmit at an ambient temperature of 20°C, when the heat generated within the gearbox is being dissipated at the same rate. Whilst these ratings can be exceeded under start up conditions, this situation could lead to overheating and subsequent damage if continuously applied.

Thermal torque ratings do not relate to mechanical gear life and are not affected by running time or momentary shock loads. If the ambient temperature is likely to exceed 20°C, this situation will have to be taken into account in the selection procedure. This is done by applying the thermal service factor given in table 4 when calculating the selection output torque.

E.g. Thermal selection torque = continuous torque requirement X thermal service factor f_T . Where intermittent running is involved it is possible the thermal limitation can be ignored, such as on a crane or which application, and when this type of operation is being considered full applicational details should be given to Renold for assessment.

Selection Procedure

The ratings tables for the single reduction wormgear units provide mechanical ratings in terms of input and output power in kW and mechanical and thermal output torque ratings in Newton Meters.

Tables 1 and 2 list the service factors relative to the operational hours each working day and the load classification with regard to the nature of the service. When determining the selection power absorbed and not the rating of the prime mover should be used.

The procedure is as follows for single reduction units:-

- a) Establish the ratio required by dividing the input speed by the output, choosing the nearest nominal ratio available from tables 7 and 8.

$$\text{Gear ratio} = \frac{\text{Input speed rev/min}}{\text{Output speed rev/min}}$$

- b) Determine the load classification from table 1 and the corresponding mechanical service factor f_D , from table 2 and the starts factor f_s from table 3.

- c) Multiply the actual power absorbed by the mechanical service factor f_D and tentatively select the size of unit by comparing this against the mechanical rating appropriate to the ratio and input speed.

$$\text{Selection Output Torque} = \text{actual output torque} \times f_D \times f_s$$

$$\text{or}$$

$$\text{Selection Output Torque} = \frac{\text{absorbed power} \times 9550 \times f_D \times f_s}{\text{output speed (rev/min)}}$$

- d) For continuous operation check that the thermal rating is at least equal to the thermal torque requirement. External cooling can be offered to increase thermal rate. Thermal torque requirement = continuous torque x thermal service factor f_T from table 4.
- e) Check the capability of the unit to withstand external loads applied to the output shaft, see tables 5 and 6.

For the selection of units from the double reduction range, the thermal rating is ignored since at the speeds involved only the mechanical rating needs to be considered.

WM Series - Selection Examples

Mechanical Selection Torque	Nm =	Actual Torque (Nm) Requirement	X	Mechanical Service (fd) Factor	X	Starts (fs) Factors
Thermal Selection Torque	Nm =	Actual Torque (Nm) Requirement	X	Thermal Service (fr) Factor		
Mechanical Selection Power	(kW) =	Actual Power (kW) Requirement	X	Mechanical Service (fd) Factor	X	Starts (fs) Factor
Thermal Selection Power	(kW) =	Actual Power (kW) Requirement	X	Thermal Service (fr) Factor		

It can be seen from the ratings tables on pages 28 - 41 that both mineral and synthetic oil ratings are included. Depending upon which type of oil is to be used inside the gear unit will determine which rating are used to make a selection.

Example 1

A right angled underdriven wormgear unit is required to drive a belt conveyor with steady load conditions for 12 hours per day, continuous running. The ambient temperature is 20°C and the prime mover is an electric motor running at 1500rpm nominal speed. Headshaft torque is 2800Nm. The gear unit ratio would be 20/1.

1. Mechanical

$$\text{Service (fd) Factor} = 1.25$$

2. Starts

$$\text{Factor (fs)} = 1.0$$

3. Thermal

$$\text{Service (ft) Factor} = 1.0$$

4. Mechanical

$$\begin{aligned} \text{Selection (Nm) Torque} &= \text{Actual (Nm) Torque} \times (\text{fd}) \times (\text{fs}) \\ &= 2800 \times 1.25 \times 1 \\ &= 3500 \text{ Nm.} \end{aligned}$$

5. Thermal

$$\begin{aligned} \text{Selection Torque (Nm)} &= \text{Actual (Nm) Torque} \times (\text{fr}) \\ &= 2800 \times 1.00 \\ &= 2800 \text{ Nm.} \end{aligned}$$

6. An 8" centre distance unit would be selected at 20/1 ratio using mineral oil. However, if synthetic oil could be used, the 7" centres unit would be suitable for the application, having a mechanical torque capacity of 2953 Nm and thermal capacity of 3831 Nm.

Example 2

A wormgear unit is to be used on a heavy duty application run at 24 hours per day continuous duty, maximum ambient temperature 40°C. The unit ratio is to be 60/1 and the electric drive motor is 1500rpm nominal speed (1440 rpm actual). The demand power from the motor is 2.80kW.

1. Mechanical

$$\text{Service (fd) Factor} = 2.00$$

2. Starts

$$\text{Factor (fs)} = 1.00$$

3. Thermal

$$\text{Service (fr) Factor} = 1.35$$

4. Mechanical

$$\begin{aligned} \text{Selection (kW) Power} &= \text{Actual} \times (\text{fd}) \times (\text{fs}) \\ &= 2.8 \times 2.0 \times 1.0 \\ &= 5.6 \text{ kW.} \end{aligned}$$

5. Thermal

$$\begin{aligned} \text{Selection (kW) Power} &= \text{Actual} \times (\text{fr}) \\ &= 2.8 \times 1.35 \\ &= 3.78 \text{ kW.} \end{aligned}$$

6. The selection for this application would be 6" centres unit at 60/1 ratio using mineral oil. The unit mechanical power rating is 5.74 kW and the thermal power rating is 8.71kW. There is no advantage in using synthetic oil in this example.

WM Series - Load Classification by Application

Table 1

Agitators		Sugar (1)	M	Medium duty	M	Individual drives	H	single acting: 1 or 2 cylinders	*
Pure liquids	S	Dredges	M	Skip hoist	M	Reversing	*	double acting: single cylinder	*
Liquids and solids	M	Cable reels	M	Laundry	M	Wire drawing and flattening machine	M	Rotary - gear type	S
Liquids-variable density	M	Conveyors	M	Washers - reversing	M	Wire winding machine	M	Rotary - lobe, vane	S
Blowers		Cutter head drives	H	Tumblers	M	Mills, rotary type		Rubber and plastics industries	
Centrifugal	S	Jig drives	H	Line shafts		Ball (1)	M	Crackers (1)	H
Lobe	M	Manoeuvring winches	M	Driving processing equipment	M	Cement kilns (1)	M	Laboratory equipment	M
Vane	S	Pumps	M	Light	M	Dryers and coolers (1)	M	Mixed mills (1)	H
Brewing and Distilling	S	Screen drive	H	Other line shafts	S	Kilns other than cement	M	Refiners (1)	M
Bottling machinery	S	Stackers	M	Lumber industry		Pebble (1)	M	Rubber calenders (1)	M
Brew kettles-continuous duty	S	Utility winches	M	Barkers, hydraulic, mechanical	M	Rod, plain & wedge bar (1)	M	Rubber mill, 2 on line (1)	M
Cookers-continuous duty	S	Dry dock cranes		Burner conveyor	M	Tumbling barrels	H	Rubber mill, 3 on line (1)	S
Mash tubs-continuous duty	S	Main hoist	(2)	Chain saw and drag saw	H	Mixers		Sheeter (1)	M
Scale hopper-frequent starts	M	Auxiliary hoist	(2)	Chain transfer	H	Concrete mixers continuous	M	Tyre building machines	*
Can filling machines	S	Boom, luffing	(2)	Craneaway transfer	H	Concrete mixers intermittent	M	Tyre and tube press openers	*
Cane knives (1)	M	Rotating, swing or slew	(3)	De-barking drum	H	Constant density	S	Tubers and strainers (1)	M
Car dumpers	H	Tracking, drive wheels	(4)	Edger feed	M	Variable density	M	Warming mills (1)	M
Car pullers	M	Elevators		Gang feed	M	Oil industry		Sand miller	M
Clarifiers	S	Bucket - uniform load	S	Green chain	M	Chillers	M	Screens	
Classifiers	M	Bucket - heavy load	M	Live rolls	H	Oil well pumping	*	Air washing	S
Clay working machinery		Bucket - continuous	S	Log deck	S	Paraffin filter press	M	Rotary, stone or gravel	M
Brick press	H	Centrifugal discharge	S	Log haul-implode	H	Rotary kilns	M	Travelling water intake	S
Briquette machine	H	Escalators	S	Log haul-well type	H	Paper mills		Sewage disposal equipment	
Clay working machinery	M	Freight	M	Log turning device	H	Agitators (mixers)	M	Bar screens	S
Pug mill	M	Gravity discharge	S	Main log conveyor	S	Barker-auxiliaries hydraulic	M	Chemical feeders	S
Compressors		Man lifts	*	Off bearing rolls	M	Barker-mechanical	H	Collectors	S
Centrifugal	S	Passenger	*	Planer feed chains	M	Barking drum	H	Dewatering screws	M
Lobe	M	Extruders (plastic)		Planer floor chains	M	Beater and pulper	M	Scum breakers	M
Reciprocating - multi-cylinder	M	Film	S	Planer tilting hoist	M	Bleacher	S	Slow or rapid mixers	M
Reciprocating - single cylinder	H	Sheet	S	Re-saw merry-go-round conveyor	M	Calenders	M	Thickeners	M
Conveyors - uniformly loaded or fed	M	Coating	S	Roll cases	H	Calenders-super	H	Vacuum filters	M
Apron	S	Rods	S	Slab conveyor	S	Converting machine except cutters, platers	M	Slab pushers	M
Assembly	S	Tubing	S	Small waste conveyor-belt	S	Conveyors	S	Steering gear	*
Belt	S	Blow moulders	M	Small waste conveyor-chain	M	Couch	M	Stokers	S
Bucket	S	Pre-plasticisers	M	Sorting table	M	Cutters	M	Sugar industry	
Chain	S	Fans	M	Tipple hoist conveyor	M	Cutters, platers	H	Cane knives (1)	M
Flight	S	Centrifugal	S	Tipple hoist drive	M	Cylinders	M	Crushers (1)	M
Oven	S	Cooling towers	S	Transfer conveyors	M	Dryers	M	Mills (1)	M
Screw	S	Induced draft	*	Transfer rolls	M	Fell stretcher	M	Textile industry	
Conveyors - heavy duty not uniformly fed		Forced draft	*	Tray feed	M	Fell whipper	H	Batchers	M
Apron	M	Induced draft	M	Trimmer feed	M	Jordans	M	Calenders	M
Assembly	M	Large, mine etc.	M	Waste conveyor	M	Log haul	H	Cards	M
Belt	M	Large, industrial	M	Machine tools		Presses	M	Dry cans	M
Bucket	M	Light, small diameter	S	Bending roll	S	Pulp machine reel	M	Dryers	M
Chain	M	Feeders	M	Punch press-gear driven	H	Stock chest	M	Dyeing machinery	M
Flight	M	Apron	M	Notching press-belt drive	*	Suction roll	M	Looms	M
Live roll	*	Belt	M	Plate planners	H	Washers and thickeners	M	Mangles	M
Oven	M	Disc	S	Tapping machine	H	Winders	M	Nappers	M
Reciprocating	H	Reciprocating	H	Other machine tools		Printing presses	*	Pads	M
Screw	H	Screw	M	Main drives	M	Pullers		Range drives	M
Shaker	M	Food industry		Auxiliary drives	S	Barge haul	H	Slashers	M
Crane Drives - not dry dock		Beef slicer	M	Metal mills		Pumps		Soapers	M
Main hoists	S	Cereal cooker	S	Drawn bench carriage and main drive	M	Centrifugal	S	Spinners	M
Bridge travel	*	Dough mixer	M	Pinch, dryer and scrubber rolls, reversing	M	Proportioning	M	Tenter frames	M
Trolley travel	*	Meat grinder	M	Slitters	H	Reciprocating	M	Washers	M
Crushers		Generators - not welding		Table conveyors non-reversing group drives	H	single acting:	*	Winders	M
Ore	H	Hammer mills				3 or more cylinders	M	Windlass	*
Stone	H	Hoists				double acting:			
		Heavy duty	H			2 or more cylinders	M		

Service Factors

Table 2 (Service Factor f_D)

Prime mover (Drive input)	Driven machinery characteristics			
	Duration Service	Steady load	Medium impulsive	Highly impulsive
Electric, Air & Hydraulic Motors or Steam Turbine (Steady input)	Intermittent-3hrs/day max	0.90	1.00	1.50
	3 - 10	1.00	1.25	1.75
	over 10	1.25	1.50	2.00
Multi-cylinder I.C. engine (Medium impulsive input)	Intermittent-3hrs/day max	1.00	1.25	1.75
	3 - 10	1.25	1.50	2.00
	over 10	1.50	1.75	2.25
Single-cylinder I.C. engine (Highly impulsive input)	Intermittent-3hrs/day max	1.25	1.50	2.00
	3 - 10	1.50	1.75	2.25
	over 10	1.75	2.00	2.50

Table 3 Factor for Starts/Hours (f_S)

Maximum number of starts per hour	5	50	100	300
Starts Factor f_S	1.0	1.1	1.15	1.2

S = Steady
M = Medium Impulsive
H = Highly Impulsive
* = Refer to Renold

- (1) = Select on 24 hours per day service factor only.
- (2) = Use service factor of 1.00 for any duration of service.
- (3) = Use service factor of 1.25 for any duration of service.
- (4) = Use service factor of 1.50 for any duration of service.

Note

Machinery characteristics and service factors listed in this catalogue are a guide only. Some applications (e.g. constant power) may require special considerations. Consult Renold Gears.

Table 4 Thermal Service Factor f_T

Ambient °C	10	20	30	40	50	60
	Temp °F	50	68	86	105	122
Factor f_T	0.87	1.0	1.16	1.35	1.62	1.97

WM Series - Overhung and Thrust Loads

Output shafts of worm gear units are frequently fitted with a spur pinion, chain pinion or belt pulley causing an overhung load to be imposed on the output shaft and bearings. These loads can generally be sustained by the gear unit; however, if the load is greater than the maximum allowable load for the unit, it may be necessary to either select a larger unit or to lessen the effect of the load on the shaft bearings. This can be done in two ways. The pinion can be mounted on a shaft in its own bearings and the shaft coupled to the gear unit; or the wheel shaft may be extended beyond the overhung load and fitted with an outboard bearing. In order to obtain the best possible arrangement for a particular application (where large over hung loads are anticipated) customers are advised to submit details of the load to our Sales Technical Staff for their consideration.

In the interests of good design, the overhung member should be fitted as close as possible to the gear case in order to minimise the stresses and reduce the deflecting moment on the unit.

The maximum imposed axial thrust and overhung loads to which the units can be subjected are given in tables 5 and 6.

Imposed axial thrust loads can also be minimised by the use of flexible couplings on the input and output shafts.

For drives where both imposed thrust and overhung loads are encountered, it is advisable to consult our Technical Sales Staff.

Where a double extension shaft is fitted, the maximum overhung loads listed apply in full to each shaft extension.

The overhung load may be calculated by the following formula:

$$\frac{9.55P \times 10^6 \times F \text{ (Newtons)}}{R \times S}$$

Where P = Power absorbed at output shaft (kW)

S = Speed of output shaft in rev/min

R = Pitch circle radius of chain pinion, spur or helical gear, or belt pulley in mm.

F = Overhung drive application factor as follows:

Chain pinion 1.00

Spur or helical gear 1.25

Vee pulley 1.50

Flat belt pulley 2.00

The overhung load capacities listed in table 5 assume the load is applied mid-way along the output shaft extension, the relevant dimension from the centre line of the unit being as given below.

Unit Size	Dimension mm
	Standard Shaft
WM4	161
WM5	193
WM6	218
WM7	238
WM8	244
WM9	268

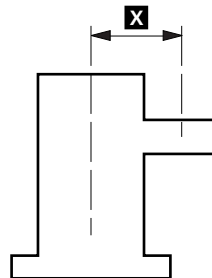

WM Series - Overhung Load Capacities**Table 5: Output Shaft Overhung Load Capacities (in newtons)****At 1450 rev/min input speed**

Ratio	Output Speed	Gear Unit Reference					
		WM4	WM5	WM6	WM7	WM8	WM9
5/1	290	10370	12870	11640	20470	26760	30080
7.5/1	193	12130	15650	18360	26480	33070	35390
10/1	145	13490	17370	20980	29450	36920	42110
12.5/1	116	14200	18630	22830	31350	38790	43710
15/1	97	14000	19820	24320	33870	42150	48050
20/1	73	14100	20140	24550	38750	48830	55700
25/1	58	13790	20320	24750	41600	51880	58790
30/1	48	13560	19140	23910	42000	55000	60000
35/1	41	13830	19410	23770	42000	55000	60000
40/1	36	13970	19760	24060	42000	55000	60000
45/1	32	14040	19940	24360	42000	55000	60000
50/1	29	14110	20160	24570	42000	55000	60000
60/1	24	14250	20470	24960	42000	55000	60000
70/1	21	14340	20730	25290	42000	55000	60000

At 960 rev/min input speed

Ratio	Output Speed	Gear Unit Reference					
		WM4	WM5	WM6	WM7	WM8	WM9
5/1	192	11480	13280	10630	20390	27340	31170
7.5/1	128	13610	17510	20760	29380	36680	38950
10/1	96	14170	19510	23520	33090	41450	47310
12.5/1	77	13960	19790	24300	35120	43520	49100
15/1	64	13720	19250	24020	37930	47270	53870
20/1	48	13860	19560	23780	42000	54840	60000
25/1	38	13440	19790	24050	42000	55000	60000
30/1	32	13150	18230	22940	42000	55000	60000
35/1	27	13530	18670	22800	42000	55000	60000
40/1	24	13730	19170	23180	42000	55000	60000
45/1	21	13810	19380	23590	42000	55000	60000
50/1	19	13890	19670	23900	42000	55000	60000
60/1	16	14070	20060	24440	42000	55000	60000
70/1	14	14200	20410	24860	42000	55000	60000

WM Series - Axial Thrust Load Capacities**Table 6: Output Shaft Axial Thrust loads (in newtons)****At 1450 rev/min input speed**

Ratio	Output Speed	Gear Unit Reference					
		WM4	WM5	WM6	WM7	WM8	WM9
5/1	290	9330	9450	7370	13220	18400	19710
7.5/1	193	12340	14270	13520	21440	28700	26590
10/1	145	14530	16900	16940	25600	34180	37380
12.5/1	116	16110	18380	19250	28100	36420	38980
15/1	97	17620	20080	21700	31780	41380	45380
20/1	73	20610	24020	26460	38750	51070	56224
25/1	58	21870	26430	29300	42300	54820	59840
30/1	48	22000	27280	31040	46750	55000	65000
35/1	41	22000	29630	33120	48220	55000	65000
40/1	36	22000	31740	35490	50000	55000	65000
45/1	32	22000	33000	37764	50000	55000	65000
50/1	29	22000	33000	39620	50000	55000	65000
60/1	24	22000	33000	43020	50000	55000	65000
70/1	21	22000	33000	44000	50000	55000	65000

At 960 rev/min input speed

Ratio	Output Speed	Gear Unit Reference					
		WM4	WM5	WM6	WM7	WM8	WM9
5/1	192	9890	9690	6660	13060	18690	20320
7.5/1	128	13680	15700	14560	23010	30940	27870
10/1	96	16110	18770	18690	28420	38020	41630
12.5/1	77	17900	20370	21180	31100	40450	43390
15/1	64	19730	22400	24030	35200	46020	50460
20/1	48	22000	26960	29630	43390	55000	62820
25/1	38	22000	29710	32880	47520	55000	65000
30/1	32	22000	30640	35850	50000	55000	65000
35/1	27	22000	33000	37250	50000	55000	65000
40/1	24	22000	33000	39940	50000	55000	65000
45/1	21	22000	33000	42564	50000	55000	65000
50/1	19	22000	33000	44000	50000	55000	65000
60/1	16	22000	33000	44000	50000	55000	65000
70/1	14	22000	33000	44000	50000	55000	65000

WM Series - Exact Ratio**Single Reduction**

Gear Size Nominal Ratio	WM4	WM5	WM6	WM7	WM8	WM9
	Actual Ratio					
5	5.16	5.16	5.13	5.13	5.13	5.13
7.5	7.25	7.25	7.40	7.40	7.40	7.33
10	9.66	9.66	9.75	9.75	9.75	9.75
12.5	12.33	12.33	12.25	12.25	12.25	12.25
15	15.5	15.5	14.66	14.66	14.66	14.66
20	20.5	20.5	20.5	20.5	20.5	20.5
25	25	24.5	24.5	24.5	24.5	24.5
30	30	30	30	29.5	29.5	29.5
35	35	35	35	35	35	34.5
40	40	40	40	40	40	40
45	45	45	45	45	45	45
50	50	50	50	50	50	50
60	60	60	60	60	60	60
70	70	70	70	70	70	70

Preferred Ratios

The preferred ratios printed in light above have been chosen with a view to providing a competitive leadtime.

WM Series - Single Reduction - Selection Data

Mineral and Synthetic Oils

Nominal ratio: 5/1 Preferred Ratio

Input rpm	Output rpm	Gear Ratings	Centre Distance											
			4"		5"		6"		7"		8"		9"	
			Min	Syn	Min	Syn	Min	Syn	Min	Syn	Min	Syn	Min	Syn
1800	360.0	Input kW, Thermal	19.7	23.6	31.5	37.8	47.4	56.8	68.7	82.4	84.8	102	114	137
		Output Torque Nm, Thermal	510	617	819	990	1225	1481	1781	2153	2199	2659	2971	3592
		Input kW, Mechanical	15.5	17.2	27.2	30.2	45.5	50.6	65.7	73.0	87.4	97.2	112	125
		Output Torque Nm, Mechanical	401	449	706	791	1177	1318	1703	1907	2269	2541	2921	3272
		Efficiency %	94.3	95.2	94.8	95.6	95.1	95.9	95.3	96.1	95.4	96.2	95.5	96.3
1500	300.0	Input kW, Thermal	16.8	20.2	26.8	32.1	40.3	48.3	58.6	70.3	72.7	87.2	98.5	118
		Output Torque Nm, Thermal	521	630	834	1009	1246	1508	1819	2200	2258	2731	3067	3709
		Input kW, Mechanical	14.1	15.6	24.6	27.3	41.0	45.5	59.5	66.1	79.6	88.5	103	115
		Output Torque Nm, Mechanical	436	488	764	856	1267	1419	1846	2067	2475	2772	3209	3594
		Efficiency %	94.0	95.0	94.5	95.4	94.8	95.6	95.1	95.9	95.3	96.0	95.4	96.2
1200	240.0	Input kW, Thermal	14.0	16.8	22.2	26.6	33.2	39.8	48.3	57.9	60.1	72.0	81.7	98.0
		Output Torque Nm, Thermal	539	653	859	1040	1279	1548	1867	2259	2326	2814	3169	3833
		Input kW, Mechanical	12.6	14.0	21.9	24.2	36.4	40.4	52.8	58.6	70.9	78.8	92.3	103
		Output Torque Nm, Mechanical	485	544	846	947	1401	1569	2039	2284	2748	3078	3582	4012
		Efficiency %	93.6	94.6	94.1	95.0	94.4	95.3	94.7	95.6	94.9	95.8	95.1	95.9
1000	200.0	Input kW, Thermal	12.2	14.6	19.2	23.0	28.6	34.2	41.4	49.7	51.5	61.8	70.1	84.0
		Output Torque Nm, Thermal	560	678	887	1074	1314	1591	1914	2317	2386	2887	3252	3935
		Input kW, Mechanical	11.5	12.7	20.1	22.2	33.5	37.2	48.2	53.5	64.0	71.0	82.8	92.0
		Output Torque Nm, Mechanical	527	591	928	1039	1544	1730	2230	2498	2965	3321	3847	4308
		Efficiency %	93.1	94.2	93.7	94.7	94.0	95.0	94.4	95.3	94.6	95.5	94.8	95.7
750	150.0	Input kW, Thermal	9.96	11.9	15.5	18.5	22.9	27.4	33.0	39.5	40.9	49.0	55.4	66.4
		Output Torque Nm, Thermal	606	734	948	1149	1392	1687	2017	2443	2507	3036	3409	4127
		Input kW, Mechanical	9.56	10.6	16.8	18.6	28.3	29.9	41.1	45.6	55.3	61.4	72.1	79.9
		Output Torque Nm, Mechanical	582	651	1027	1151	1723	1844	2519	2821	3400	3808	4439	4972
		Efficiency %	92.4	93.6	93.0	94.1	93.4	94.5	93.8	94.8	94.1	95.0	94.3	95.3
500	100.0	Input kW, Thermal	7.78	9.30	11.9	14.2	17.3	20.7	24.7	29.6	30.4	36.4	40.9	49.0
		Output Torque Nm, Thermal	702	851	1081	1311	1566	1900	2243	2720	2769	3356	3739	4530
		Input kW, Mechanical	7.62	8.41	13.4	14.8	20.0	20.0	32.4	35.9	43.5	48.1	56.4	62.4
		Output Torque Nm, Mechanical	687	770	1216	1362	1811	1830	2947	3300	3965	4441	5160	5779
		Efficiency %	91.4	92.8	92.0	93.3	92.3	93.6	92.8	94.0	93.1	94.3	93.4	94.5
250	50.0	Input kW, Thermal	5.62	6.69	8.38	10.0	11.9	14.2	16.6	19.9	20.2	24.1	26.7	32.0
		Output Torque Nm, Thermal	992	1205	1490	1810	2110	2565	2963	3600	3606	4378	4797	5822
		Input kW, Mechanical	4.62	4.60	7.89	7.86	10.1	10.0	18.3	18.3	28.0	28.2	36.6	39.4
		Output Torque Nm, Mechanical	816	827	1402	1421	1781	1804	3266	3306	5010	5115	6580	7181
		Efficiency %	89.5	91.1	90.1	91.6	90.4	92.0	91.0	92.4	91.3	92.7	91.7	93.0
Max Standard Shaft Torque Nm			1800	1800	3085	3085	4960	4960	8140	8140	8140	8140	7370*	7370*

Maximum torques stated apply for uniform load applications (starts / Hour < =5)

For applications with combinations of high torques, overhung loads, or number of starts, consult Renold

* WM 9 unit only: For torques higher than the stated maximum, two keyways and high tensile steel output shaft must be specified.

WM Series - Single Reduction - Selection Data

Mineral and Synthetic Oils

Nominal ratio: 7.5/1 Non Preferred Ratio

Input rpm	Output rpm	Gear Ratings	Centre Distance											
			4"		5"		6"		7"		8"		9"	
			Min	Syn	Min	Syn	Min	Syn	Min	Syn	Min	Syn	Min	Syn
1800	240.0	Input kW, Thermal	17.6	21.0	28.3	33.8	43.4	51.9	63.0	75.4	78.4	93.9	108	129
		Output Torque Nm, Thermal	633	765	1025	1239	1612	1947	2346	2834	2926	3535	3987	4817
		Input kW, Mechanical	11.4	12.6	19.0	21.1	33.4	37.0	47.7	52.9	63.6	70.7	96.8	108
		Output Torque Nm, Mechanical	409	458	689	772	1238	1387	1774	1987	2372	2657	3586	4017
		Efficiency %	93.5	94.5	94.0	95.0	94.5	95.4	94.8	95.6	95.0	95.8	95.2	96.0
1500	200.0	Input kW, Thermal	15.0	17.9	24.0	28.7	36.7	44.0	53.3	63.8	66.6	79.7	91.5	110
		Output Torque Nm, Thermal	645	780	1041	1258	1632	1972	2376	2871	2973	3592	4059	4905
		Input kW, Mechanical	10.5	11.6	17.4	19.3	30.2	33.5	42.9	47.6	57.5	63.9	88.1	97.8
		Output Torque Nm, Mechanical	450	504	752	842	1340	1501	1908	2137	2568	2877	3907	4375
		Efficiency %	93.2	94.2	93.7	94.7	94.2	95.1	94.5	95.4	94.7	95.6	95.0	95.8
1200	160.0	Input kW, Thermal	12.5	14.9	19.9	23.7	30.2	36.1	43.7	52.3	54.6	65.3	75.0	89.8
		Output Torque Nm, Thermal	668	808	1070	1294	1669	2018	2424	2930	3035	3668	4144	5009
		Input kW, Mechanical	9.19	10.2	15.5	17.2	27.1	30.0	38.6	42.9	51.5	57.2	78.8	87.5
		Output Torque Nm, Mechanical	491	550	833	933	1497	1677	2142	2399	2863	3207	4355	4878
		Efficiency %	92.7	93.8	93.2	94.3	93.8	94.8	94.1	95.1	94.4	95.3	94.7	95.6
1000	133.3	Input kW, Thermal	10.9	13.0	17.2	20.5	26.0	31.0	37.4	44.7	46.6	55.8	64.0	76.6
		Output Torque Nm, Thermal	695	841	1105	1336	1713	2072	2479	2998	3100	3747	4226	5109
		Input kW, Mechanical	8.20	9.07	13.8	15.3	24.1	26.7	34.7	38.4	46.6	51.6	71.4	79.2
		Output Torque Nm, Mechanical	524	587	888	995	1593	1784	2297	2572	3095	3466	4717	5283
		Efficiency %	92.2	93.4	92.8	94.0	93.4	94.4	93.8	94.8	94.1	95.0	94.4	95.3
750	100.0	Input kW, Thermal	8.91	10.6	13.9	16.6	20.8	24.8	29.7	35.6	36.9	44.1	50.4	60.3
		Output Torque Nm, Thermal	753	912	1183	1431	1816	2198	2609	3157	3248	3928	4409	5332
		Input kW, Mechanical	7.01	7.73	11.7	13.0	20.5	22.7	29.1	32.2	38.8	43.0	59.4	65.8
		Output Torque Nm, Mechanical	592	663	997	1116	1789	2004	2555	2862	3415	3825	5203	5828
		Efficiency %	91.5	92.8	92.1	93.4	92.7	93.9	93.1	94.2	93.4	94.5	93.7	94.8
500	66.7	Input kW, Thermal	7.01	8.35	10.7	12.8	15.8	18.9	22.4	26.7	27.5	32.9	37.2	44.5
		Output Torque Nm, Thermal	878	1063	1355	1641	2051	2484	2911	3524	3593	4348	4835	5852
		Input kW, Mechanical	5.43	5.98	9.17	10.1	16.0	17.7	22.7	25.1	30.3	33.5	46.6	51.6
		Output Torque Nm, Mechanical	679	761	1155	1294	2071	2319	2957	3312	3956	4431	6063	6791
		Efficiency %	90.3	91.9	91.0	92.4	91.6	93.0	92.1	93.3	92.4	93.6	92.8	94.0
250	33.3	Input kW, Thermal	5.12	6.08	7.64	9.08	11.0	13.1	15.2	18.2	18.5	22.0	24.6	29.3
		Output Torque Nm, Thermal	1254	1521	1885	2285	2794	3387	3886	4710	4721	5721	6257	7583
		Input kW, Mechanical	3.44	3.78	5.85	6.42	10.2	10.5	14.7	16.1	19.6	21.6	30.2	32.7
		Output Torque Nm, Mechanical	842	944	1441	1614	2598	2705	3735	4184	5027	5630	7702	8470
		Efficiency %	88.4	90.2	89.1	90.8	89.7	91.3	90.1	91.7	90.5	92.0	90.9	92.4
Max Standard Shaft Torque Nm			1800	1800	3085	3085	4960	4960	8140	8140	8140	8140	7370*	7370*

Maximum torques stated apply for uniform load applications (starts / Hour < =5)

For applications with combinations of high torques, overhung loads, or number of starts, consult Renold

* WM 9 unit only: For torques higher than the stated maximum, two keyways and high tensile steel output shaft must be specified.

WM Series - Single Reduction - Selection Data

Mineral and Synthetic Oils

Nominal ratio: 10/1 Preferred Ratio

Input rpm	Output rpm	Gear Ratings	Centre Distance											
			4"		5"		6"		7"		8"		9"	
			Min	Syn	Min	Syn	Min	Syn	Min	Syn	Min	Syn	Min	Syn
1800	180.0	Input kW, Thermal	15.1	18.0	24.3	29.0	38.5	46.0	56.0	67.0	70.1	83.9	95.7	114
		Output Torque Nm, Thermal	717	866	1162	1404	1871	2260	2732	3300	3428	4140	4686	5658
		Input kW, Mechanical	10.0	11.1	16.6	18.4	27.3	30.2	39.3	43.6	52.6	58.4	68.4	75.9
		Output Torque Nm, Mechanical	475	532	793	889	1323	1482	1913	2143	2568	2876	3342	3743
		Efficiency %	92.5	93.7	93.1	94.1	93.8	94.8	94.1	95.0	94.3	95.2	94.5	95.4
1500	150.0	Input kW, Thermal	12.9	15.3	20.6	24.6	32.5	38.9	47.3	56.5	59.3	70.9	81.0	96.8
		Output Torque Nm, Thermal	731	883	1179	1424	1890	2283	2757	3330	3465	4185	4745	5729
		Input kW, Mechanical	9.00	9.94	15.1	16.8	25.0	27.7	36.3	40.2	48.5	53.8	63.0	69.9
		Output Torque Nm, Mechanical	510	571	864	967	1450	1624	2113	2366	2832	3172	3689	4132
		Efficiency %	92.1	93.3	92.7	93.8	93.4	94.5	93.8	94.8	94.1	95.0	94.3	95.2
1200	120.0	Input kW, Thermal	10.7	12.8	17.1	20.4	26.7	31.9	38.7	46.2	48.5	57.9	66.1	79.0
		Output Torque Nm, Thermal	757	915	1212	1464	1930	2332	2805	3389	3523	4256	4822	5824
		Input kW, Mechanical	7.87	8.69	13.1	14.5	21.7	24.0	31.8	35.2	42.6	47.2	55.6	61.6
		Output Torque Nm, Mechanical	554	620	927	1039	1564	1752	2300	2576	3098	3470	4049	4534
		Efficiency %	91.5	92.8	92.1	93.4	92.9	94.0	93.3	94.4	93.7	94.7	93.9	94.9
1000	100.0	Input kW, Thermal	9.36	11.1	14.8	17.6	23.0	27.4	33.1	39.5	41.4	49.4	56.3	67.3
		Output Torque Nm, Thermal	787	952	1251	1512	1981	2394	2867	3464	3593	4341	4907	5928
		Input kW, Mechanical	7.10	7.83	11.9	13.1	19.5	21.6	28.3	31.3	37.8	41.9	49.3	54.6
		Output Torque Nm, Mechanical	596	668	1004	1125	1681	1882	2448	2741	3285	3680	4289	4803
		Efficiency %	91.0	92.4	91.7	93.0	92.5	93.7	92.9	94.0	93.3	94.3	93.5	94.6
750	75.0	Input kW, Thermal	7.70	9.15	12.0	14.3	18.5	22.0	26.4	31.4	32.7	39.1	44.3	52.9
		Output Torque Nm, Thermal	855	1034	1341	1621	2103	2543	3019	3649	3762	4547	5113	6179
		Input kW, Mechanical	5.99	6.60	9.99	11.0	16.4	18.1	24.0	26.6	32.2	35.6	41.9	46.3
		Output Torque Nm, Mechanical	665	745	1116	1250	1871	2096	2752	3083	3702	4146	4829	5408
		Efficiency %	90.1	91.7	90.8	92.3	91.7	93.0	92.2	93.4	92.6	93.7	92.9	94.0
500	50.0	Input kW, Thermal	6.08	7.22	9.30	11.0	14.1	16.8	19.9	23.7	24.5	29.2	32.8	39.1
		Output Torque Nm, Thermal	999	1209	1540	1862	2383	2883	3376	4084	4168	5041	5613	6787
		Input kW, Mechanical	4.56	5.01	7.74	8.51	12.8	14.1	18.7	20.6	25.0	27.6	32.5	35.9
		Output Torque Nm, Mechanical	748	837	1280	1433	2158	2417	3171	3551	4260	4772	5561	6228
		Efficiency %	88.9	90.6	89.6	91.2	90.6	92.1	91.1	92.5	91.5	92.8	91.8	93.1
250	25.0	Input kW, Thermal	4.48	5.29	6.66	7.89	9.91	11.8	13.7	16.3	16.5	19.7	21.8	26.0
		Output Torque Nm, Thermal	1435	1737	2153	2607	3268	3958	4538	5495	5511	6672	7303	8840
		Input kW, Mechanical	2.90	3.18	4.93	5.40	8.14	8.25	11.9	13.1	15.9	17.5	20.7	22.8
		Output Torque Nm, Mechanical	929	1040	1591	1782	2682	2775	3942	4415	5297	5933	6921	7752
		Efficiency %	86.7	88.7	87.4	89.4	88.5	90.3	89.0	90.7	89.4	91.1	89.8	91.4
Max Standard Shaft Torque Nm			1800	1800	3085	3085	4960	4960	8140	8140	8140	8140	7370*	7370*

Maximum torques stated apply for uniform load applications (starts / Hour < =5)

For applications with combinations of high torques, overhung loads, or number of starts, consult Renold

* WM 9 unit only: For torques higher than the stated maximum, two keyways and high tensile steel output shaft must be specified.

WM Series - Single Reduction - Selection Data

Mineral and Synthetic Oils

Nominal ratio: 12.5/1 Non Preferred Ratio

Input rpm	Output rpm	Gear Ratings	Centre Distance											
			4"		5"		6"		7"		8"		9"	
			Min	Syn	Min	Syn	Min	Syn	Min	Syn	Min	Syn	Min	Syn
1800	144.0	Input kW, Thermal	12.9	15.4	20.9	24.8	33.8	40.3	48.5	57.9	60.7	72.5	83.0	99.1
		Output Torque Nm, Thermal	775	935	1258	1519	2043	2466	2946	3555	3696	4461	5064	6111
		Input kW, Mechanical	9.21	10.2	16.5	18.2	25.4	28.1	39.2	43.5	55.4	61.4	74.4	82.5
		Output Torque Nm, Mechanical	551	617	993	1112	1532	1716	2379	2665	3370	3775	4536	5081
		Efficiency %	91.3	92.7	92.1	93.3	93.0	94.1	93.3	94.3	93.6	94.6	93.8	94.8
1500	120.0	Input kW, Thermal	11.1	13.1	17.7	21.1	28.5	34.0	41.0	48.8	51.3	61.2	70.2	83.7
		Output Torque Nm, Thermal	790	954	1275	1540	2060	2488	2970	3585	3730	4503	5118	6177
		Input kW, Mechanical	8.19	9.03	14.7	16.2	22.7	25.1	35.3	39.1	50.0	55.4	67.5	74.8
		Output Torque Nm, Mechanical	584	654	1056	1183	1635	1831	2559	2866	3638	4075	4922	5512
		Efficiency %	90.8	92.2	91.6	92.9	92.5	93.7	92.9	94.0	93.3	94.3	93.5	94.5
1200	96.0	Input kW, Thermal	9.24	11.0	14.7	17.4	23.4	27.9	33.5	39.9	41.9	50.0	57.3	68.3
		Output Torque Nm, Thermal	819	988	1311	1583	2103	2540	3020	3646	3789	4574	5195	6271
		Input kW, Mechanical	7.27	8.01	12.9	14.2	19.8	21.8	30.5	33.8	43.2	47.8	58.7	64.9
		Output Torque Nm, Mechanical	643	720	1151	1289	1773	1985	2750	3079	3908	4377	5322	5961
		Efficiency %	90.1	91.7	90.9	92.3	92.0	93.2	92.4	93.6	92.7	93.9	93.1	94.2
1000	80.0	Input kW, Thermal	8.07	9.57	12.7	15.1	20.2	24.0	28.7	34.2	35.8	42.6	48.8	58.1
		Output Torque Nm, Thermal	852	1029	1354	1635	2159	2609	3086	3727	3862	4663	5283	6379
		Input kW, Mechanical	6.50	7.16	11.6	12.8	17.9	19.8	27.7	30.6	38.9	43.0	52.0	57.5
		Output Torque Nm, Mechanical	686	768	1239	1387	1915	2145	2976	3333	4201	4705	5633	6309
		Efficiency %	89.6	91.2	90.4	91.9	91.5	92.8	91.9	93.2	92.3	93.5	92.6	93.8
750	60.0	Input kW, Thermal	6.65	7.88	10.3	12.3	16.2	19.3	22.9	27.2	28.4	33.7	38.4	45.8
		Output Torque Nm, Thermal	926	1119	1452	1754	2295	2774	3250	3926	4044	4884	5503	6646
		Input kW, Mechanical	5.46	6.00	9.72	10.7	14.9	16.4	23.2	25.6	32.9	36.3	44.4	49.0
		Output Torque Nm, Mechanical	760	851	1365	1529	2103	2356	3290	3684	4692	5255	6360	7124
		Efficiency %	88.6	90.3	89.5	91.1	90.6	92.1	91.0	92.4	91.4	92.8	91.8	93.1
500	40.0	Input kW, Thermal	5.28	6.24	8.05	9.53	12.5	14.8	17.3	20.6	21.3	25.3	28.5	33.9
		Output Torque Nm, Thermal	1085	1312	1671	2019	2608	3153	3639	4398	4484	5418	6044	7303
		Input kW, Mechanical	4.20	4.60	7.56	8.30	11.6	12.8	18.1	20.0	25.6	28.2	34.5	38.0
		Output Torque Nm, Mechanical	863	967	1569	1757	2431	2722	3809	4266	5414	6063	7313	8190
		Efficiency %	87.2	89.1	88.1	89.9	89.3	91.0	89.8	91.4	90.2	91.7	90.6	92.1
250	20.0	Input kW, Thermal	3.91	4.61	5.81	6.85	8.82	10.4	12.0	14.2	14.5	17.1	19.1	22.6
		Output Torque Nm, Thermal	1564	1892	2345	2836	3598	4354	4902	5930	5943	7187	7881	9530
		Input kW, Mechanical	2.63	2.86	4.74	5.17	6.68	6.61	11.4	12.5	16.2	17.8	21.8	24.0
		Output Torque Nm, Mechanical	1049	1175	1911	2140	2723	2755	4669	5229	6659	7459	9029	10113
		Efficiency %	84.8	87.1	85.6	87.8	87.1	89.0	87.5	89.4	87.9	89.8	88.3	90.1
Max Standard Shaft Torque Nm			1800	1800	3085	3085	4960	4960	8140	8140	8140	8140	7370*	7370*

Maximum torques stated apply for uniform load applications (starts / Hour < =5)

For applications with combinations of high torques, overhung loads, or number of starts, consult Renold

* WM 9 unit only: For torques higher than the stated maximum, two keyways and high tensile steel output shaft must be specified.

WM Series - Single Reduction - Selection Data

Mineral and Synthetic Oils

Nominal ratio: 15/1 Preferred Ratio

Input rpm	Output rpm	Gear Ratings	Centre Distance											
			4"		5"		6"		7"		8"		9"	
			Min	Syn	Min	Syn	Min	Syn	Min	Syn	Min	Syn	Min	Syn
1800	120.0	Input kW, Thermal	10.8	12.8	18.0	21.4	29.5	35.2	43.0	51.2	53.9	64.3	73.7	87.9
		Output Torque Nm, Thermal	797	962	1348	1626	2118	2556	3098	3738	3894	4699	5339	6442
		Input kW, Mechanical	8.44	9.29	15.0	16.5	22.8	25.2	34.0	37.6	47.2	52.2	61.0	67.5
		Output Torque Nm, Mechanical	623	697	1120	1254	1630	1825	2444	2737	3404	3812	4412	4942
		Efficiency %	89.7	91.3	90.9	92.3	92.0	93.2	92.4	93.6	92.8	93.9	93.0	94.1
1500	100.0	Input kW, Thermal	9.23	10.9	15.3	18.2	25.0	29.7	36.3	43.2	45.5	54.2	62.2	74.2
		Output Torque Nm, Thermal	812	980	1366	1648	2137	2579	3120	3766	3925	4737	5388	6501
		Input kW, Mechanical	7.64	8.40	13.4	14.8	20.2	22.3	30.2	33.4	42.2	46.7	54.8	60.7
		Output Torque Nm, Mechanical	672	752	1195	1339	1725	1932	2598	2910	3641	4078	4743	5312
		Efficiency %	89.1	90.7	90.3	91.8	91.5	92.8	92.0	93.2	92.4	93.6	92.7	93.8
1200	80.0	Input kW, Thermal	7.72	9.14	12.7	15.1	20.6	24.4	29.7	35.3	37.2	44.2	50.8	60.4
		Output Torque Nm, Thermal	842	1016	1403	1694	2182	2634	3171	3828	3983	4807	5461	6591
		Input kW, Mechanical	6.72	7.38	11.9	13.1	17.9	19.7	26.4	29.2	36.4	40.2	47.4	52.4
		Output Torque Nm, Mechanical	732	819	1312	1469	1896	2123	2818	3156	3902	4370	5095	5707
		Efficiency %	88.3	90.1	89.6	91.2	90.9	92.3	91.4	92.7	91.8	93.1	92.1	93.4
1000	66.7	Input kW, Thermal	6.75	7.98	11.0	13.0	17.7	21.0	25.5	30.3	31.8	37.8	43.2	51.5
		Output Torque Nm, Thermal	876	1058	1450	1750	2240	2704	3241	3912	4059	4899	5551	6700
		Input kW, Mechanical	5.96	6.54	10.5	11.6	16.0	17.6	23.9	26.4	33.2	36.6	42.9	47.4
		Output Torque Nm, Mechanical	773	866	1386	1552	2024	2267	3043	3408	4245	4755	5512	6174
		Efficiency %	87.6	89.5	88.9	90.6	90.3	91.8	90.8	92.3	91.3	92.6	91.7	92.9
750	50.0	Input kW, Thermal	5.58	6.58	8.98	10.6	14.3	16.9	20.3	24.1	25.2	29.9	34.1	40.5
		Output Torque Nm, Thermal	953	1151	1557	1881	2380	2874	3414	4122	4250	5132	5781	6979
		Input kW, Mechanical	5.04	5.51	8.90	9.77	13.4	14.8	20.0	22.0	27.8	30.6	35.9	39.6
		Output Torque Nm, Mechanical	860	963	1544	1730	2238	2507	3360	3763	4689	5252	6090	6820
		Efficiency %	86.5	88.5	87.9	89.7	89.3	91.0	89.9	91.5	90.4	91.9	90.8	92.2
500	33.3	Input kW, Thermal	4.44	5.23	7.02	8.29	11.0	13.0	15.4	18.3	18.9	22.4	25.4	30.1
		Output Torque Nm, Thermal	1117	1349	1795	2169	2703	3265	3826	4622	4716	5696	6353	7673
		Input kW, Mechanical	3.90	4.24	6.89	7.19	10.4	11.5	15.6	17.1	21.6	23.8	27.9	30.7
		Output Torque Nm, Mechanical	980	1093	1761	1881	2572	2880	3866	4329	5393	6040	7002	7842
		Efficiency %	84.9	87.1	86.3	88.4	87.9	89.7	88.5	90.3	89.0	90.7	89.4	91.1
250	16.7	Input kW, Thermal	3.31	3.88	5.10	6.00	7.78	9.17	10.7	12.7	12.9	15.3	17.0	20.1
		Output Torque Nm, Thermal	1611	1947	2530	3058	3725	4504	5166	6245	6264	7571	8300	10031
		Input kW, Mechanical	2.21	2.16	3.73	3.66	6.51	6.97	9.77	10.7	13.6	14.9	17.7	19.4
		Output Torque Nm, Mechanical	1073	1083	1846	1864	3113	3420	4708	5272	6611	7404	8640	9677
		Efficiency %	82.1	84.6	83.6	86.0	85.4	87.6	86.0	88.1	86.5	88.5	86.9	88.9
Max Standard Shaft Torque Nm			1800	1800	3085	3085	4960	4960	8140	8140	8140	8140	7370*	7370*

Maximum torques stated apply for uniform load applications (starts / Hour < =5)

For applications with combinations of high torques, overhung loads, or number of starts, consult Renold

* WM 9 unit only: For torques higher than the stated maximum, two keyways and high tensile steel output shaft must be specified.

WM Series - Single Reduction - Selection Data

Mineral and Synthetic Oils

Nominal ratio: 20/1 Preferred Ratio

Input rpm	Output rpm	Gear Ratings	Centre Distance											
			4"		5"		6"		7"		8"		9"	
			Min	Syn	Min	Syn	Min	Syn	Min	Syn	Min	Syn	Min	Syn
1800	90.0	Input kW, Thermal	8.99	10.6	14.5	17.1	22.1	26.2	32.2	38.2	40.2	47.7	54.9	65.2
		Output Torque Nm, Thermal	859	1036	1396	1684	2154	2598	3151	3801	3955	4770	5422	6539
		Input kW, Mechanical	6.15	6.75	10.7	11.8	17.4	19.1	25.4	28.0	34.1	37.6	44.2	48.7
		Output Torque Nm, Mechanical	586	656	1035	1159	1687	1890	2487	2785	3350	3752	4350	4872
		Efficiency %	87.5	89.4	88.5	90.2	89.3	90.9	89.9	91.4	90.3	91.8	90.6	92.0
1500	75.0	Input kW, Thermal	7.70	9.09	12.3	14.5	18.7	22.2	27.2	32.2	34.0	40.3	46.5	55.1
		Output Torque Nm, Thermal	875	1056	1415	1707	2174	2622	3176	3831	3989	4811	5476	6605
		Input kW, Mechanical	5.56	6.09	9.88	10.8	15.7	17.2	22.6	24.9	30.2	33.2	39.3	43.3
		Output Torque Nm, Mechanical	630	705	1132	1268	1814	2031	2636	2953	3536	3960	4626	5181
		Efficiency %	86.8	88.8	87.9	89.7	88.7	90.4	89.3	90.9	89.8	91.3	90.1	91.6
1200	60.0	Input kW, Thermal	6.46	7.61	10.2	12.1	15.5	18.3	22.3	26.4	27.9	33.0	38.0	45.0
		Output Torque Nm, Thermal	908	1096	1454	1754	2219	2677	3229	3895	4049	4884	5555	6700
		Input kW, Mechanical	4.83	5.28	8.63	9.46	13.8	15.2	20.1	22.1	26.9	29.6	34.7	38.2
		Output Torque Nm, Mechanical	677	758	1225	1372	1981	2218	2907	3256	3907	4375	5065	5672
		Efficiency %	85.9	88.0	87.0	88.9	87.9	89.7	88.5	90.3	89.1	90.7	89.5	91.1
1000	50.0	Input kW, Thermal	5.67	6.66	8.89	10.5	13.3	15.7	19.2	22.7	23.8	28.2	32.5	38.4
		Output Torque Nm, Thermal	946	1142	1502	1813	2278	2748	3299	3980	4126	4977	5648	6812
		Input kW, Mechanical	4.35	4.75	7.74	8.46	12.3	13.5	17.9	19.6	24.0	26.4	31.2	34.3
		Output Torque Nm, Mechanical	725	812	1306	1463	2105	2357	3071	3440	4157	4655	5424	6075
		Efficiency %	85.1	87.3	86.2	88.3	87.1	89.1	87.8	89.7	88.4	90.1	88.9	90.5
750	37.5	Input kW, Thermal	4.70	5.52	7.27	8.55	10.8	12.7	15.4	18.1	19.0	22.4	25.7	30.3
		Output Torque Nm, Thermal	1030	1244	1614	1948	2420	2920	3475	4193	4320	5212	5881	7095
		Input kW, Mechanical	3.66	3.98	6.51	7.11	10.4	11.3	15.1	16.6	20.2	22.2	26.2	28.7
		Output Torque Nm, Mechanical	800	896	1444	1617	2322	2600	3419	3830	4610	5163	5991	6710
		Efficiency %	83.9	86.2	85.0	87.2	85.9	88.0	86.6	88.6	87.2	89.1	87.7	89.6
500	25.0	Input kW, Thermal	3.76	4.40	5.72	6.70	8.34	9.79	11.7	13.8	14.3	16.9	19.2	22.6
		Output Torque Nm, Thermal	1211	1462	1862	2248	2746	3315	3892	4697	4791	5782	6460	7795
		Input kW, Mechanical	2.80	3.04	4.99	5.43	8.03	8.75	11.7	12.8	15.6	17.0	20.1	21.9
		Output Torque Nm, Mechanical	899	1006	1624	1819	2643	2960	3882	4347	5214	5840	6751	7561
		Efficiency %	82.0	84.6	83.1	85.6	84.1	86.4	84.8	87.1	85.4	87.6	86.0	88.1
250	12.5	Input kW, Thermal	2.83	3.30	4.19	4.88	5.96	6.97	8.21	9.60	9.87	11.6	13.0	15.2
		Output Torque Nm, Thermal	1755	2120	2627	3173	3782	4568	5250	6340	6358	7676	8431	10179
		Input kW, Mechanical	1.63	1.58	3.13	3.31	5.05	5.48	7.39	8.02	9.90	10.7	12.8	13.9
		Output Torque Nm, Mechanical	1006	1015	1959	2148	3202	3586	4724	5291	6376	7141	8295	9291
		Efficiency %	79.0	81.9	80.0	82.9	80.9	83.7	81.7	84.3	82.3	84.8	82.8	85.3
Max Standard Shaft Torque Nm			1800	1800	3085	3085	4960	4960	8140	8140	8140	8140	7370*	7370*

Maximum torques stated apply for uniform load applications (starts / Hour < =5)

For applications with combinations of high torques, overhung loads, or number of starts, consult Renold

* WM 9 unit only: For torques higher than the stated maximum, two keyways and high tensile steel output shaft must be specified.

WM Series - Single Reduction - Selection Data

Mineral and Synthetic Oils

Nominal ratio: 25/1 Preferred Ratio

Input rpm	Output rpm	Gear Ratings	Centre Distance											
			4"		5"		6"		7"		8"		9"	
			Min	Syn	Min	Syn	Min	Syn	Min	Syn	Min	Syn	Min	Syn
1800	72.0	Input kW, Thermal	6.92	8.12	12.9	15.3	19.8	23.4	28.8	34.0	36.0	42.7	49.2	58.3
		Output Torque Nm, Thermal	773	932	1469	1772	2269	2737	3321	4005	4182	5043	5738	6919
		Input kW, Mechanical	6.32	6.89	8.87	9.73	14.1	15.4	20.8	22.8	29.5	32.5	39.9	44.0
		Output Torque Nm, Mechanical	705	790	1004	1125	1608	1800	2393	2680	3421	3832	4647	5204
		Efficiency %	84.1	86.4	87.1	89.0	88.0	89.8	88.6	90.3	89.1	90.8	89.5	91.1
1500	60.0	Input kW, Thermal	5.94	6.96	11.0	13.0	16.8	19.8	24.3	28.7	30.4	36.0	41.6	49.2
		Output Torque Nm, Thermal	788	950	1488	1795	2288	2760	3342	4031	4210	5077	5781	6971
		Input kW, Mechanical	5.70	6.20	8.00	8.76	12.8	14.0	18.9	20.8	26.6	29.2	36.0	39.6
		Output Torque Nm, Mechanical	755	845	1078	1207	1743	1952	2600	2912	3668	4108	4994	5593
		Efficiency %	83.2	85.6	86.4	88.3	87.3	89.2	88.0	89.8	88.6	90.3	89.0	90.7
1200	48.0	Input kW, Thermal	5.00	5.84	9.16	10.8	13.8	16.3	20.0	23.5	24.9	29.4	34.0	40.2
		Output Torque Nm, Thermal	816	984	1529	1845	2336	2817	3395	4095	4268	5147	5852	7058
		Input kW, Mechanical	4.99	5.42	6.99	7.63	11.1	12.1	16.6	18.2	23.4	25.7	31.6	34.7
		Output Torque Nm, Mechanical	815	913	1163	1303	1867	2091	2814	3151	4010	4491	5441	6093
		Efficiency %	82.0	84.6	85.4	87.5	86.4	88.4	87.1	89.0	87.8	89.6	88.3	90.0
1000	40.0	Input kW, Thermal	4.39	5.12	7.97	9.37	12.0	14.1	17.2	20.2	21.4	25.2	29.0	34.3
		Output Torque Nm, Thermal	848	1023	1581	1908	2398	2893	3469	4184	4347	5244	5946	7171
		Input kW, Mechanical	4.49	4.86	6.26	6.83	10.0	11.0	14.8	16.2	20.9	22.9	28.1	30.9
		Output Torque Nm, Mechanical	868	972	1239	1388	2006	2247	2992	3351	4255	4765	5765	6457
		Efficiency %	81.0	83.7	84.6	86.8	85.6	87.7	86.4	88.4	87.0	88.9	87.5	89.4
750	30.0	Input kW, Thermal	3.64	4.24	6.54	7.67	9.69	11.4	13.8	16.2	17.0	20.0	23.0	27.1
		Output Torque Nm, Thermal	921	1111	1701	2053	2550	3077	3656	4410	4552	5492	6190	7467
		Input kW, Mechanical	3.78	4.09	5.25	5.72	8.35	9.11	12.4	13.5	17.6	19.2	23.8	26.0
		Output Torque Nm, Mechanical	955	1070	1364	1528	2195	2458	3292	3687	4710	5275	6402	7170
		Efficiency %	79.4	82.3	83.2	85.6	84.3	86.5	85.1	87.2	85.7	87.8	86.3	88.4
500	20.0	Input kW, Thermal	2.93	3.39	5.16	6.03	7.52	8.80	10.5	12.4	12.9	15.1	17.2	20.2
		Output Torque Nm, Thermal	1077	1299	1966	2373	2899	3499	4102	4949	5056	6100	6807	8213
		Input kW, Mechanical	2.92	3.14	4.03	4.37	6.50	7.06	9.68	10.5	13.7	14.9	18.3	20.0
		Output Torque Nm, Mechanical	1073	1202	1532	1716	2503	2803	3766	4217	5356	5999	7239	8108
		Efficiency %	77.1	80.2	81.3	83.9	82.3	84.8	83.1	85.6	83.8	86.2	84.4	86.7
250	10.0	Input kW, Thermal	2.21	2.54	3.81	4.42	5.42	6.30	7.44	8.67	8.94	10.4	11.8	13.7
		Output Torque Nm, Thermal	1547	1867	2784	3362	4007	4838	5553	6704	6730	8124	8913	10759
		Input kW, Mechanical	1.83	1.96	2.51	2.56	4.06	4.38	6.06	6.55	8.56	9.27	11.5	12.5
		Output Torque Nm, Mechanical	1280	1434	1831	1943	2997	3357	4518	5061	6442	7215	8726	9773
		Efficiency %	73.3	76.7	78.0	81.0	79.0	81.9	79.7	82.6	80.4	83.2	81.0	83.7
Max Standard Shaft Torque Nm			1800	1800	3085	3085	4960	4960	8140	8140	8140	8140	7370*	7370*

Maximum torques stated apply for uniform load applications (starts / Hour < =5)

For applications with combinations of high torques, overhung loads, or number of starts, consult Renold

* WM 9 unit only: For torques higher than the stated maximum, two keyways and high tensile steel output shaft must be specified.

WM Series - Single Reduction - Selection Data

Mineral and Synthetic Oils

Nominal ratio: 30/1 Preferred Ratio

Input rpm	Output rpm	Gear Ratings	Centre Distance											
			4"		5"		6"		7"		8"		9"	
			Min	Syn	Min	Syn	Min	Syn	Min	Syn	Min	Syn	Min	Syn
1800	60.0	Input kW, Thermal	6.57	7.70	10.5	12.4	16.1	18.9	25.8	30.5	34.0	40.2	44.3	52.4
		Output Torque Nm, Thermal	872	1051	1418	1710	2185	2635	3539	4267	4719	5690	6136	7398
		Input kW, Mechanical	5.90	6.42	9.96	10.9	14.2	15.5	16.2	17.8	23.6	25.9	31.2	34.3
		Output Torque Nm, Mechanical	781	875	1340	1501	1924	2155	2213	2479	3263	3654	4307	4824
		Efficiency %	83.3	85.7	84.5	86.8	85.4	87.5	87.2	89.0	88.3	90.0	88.2	90.0
1500	50.0	Input kW, Thermal	5.65	6.61	9.00	10.5	13.6	16.0	21.8	25.7	28.6	33.8	37.4	44.1
		Output Torque Nm, Thermal	889	1072	1437	1733	2206	2659	3557	4289	4732	5707	6164	7433
		Input kW, Mechanical	5.28	5.74	8.91	9.71	12.8	13.9	14.7	16.1	21.3	23.4	28.0	30.7
		Output Torque Nm, Mechanical	830	930	1424	1595	2065	2313	2382	2668	3515	3936	4610	5163
		Efficiency %	82.3	84.8	83.6	86.0	84.6	86.8	86.5	88.5	87.7	89.5	87.6	89.5
1200	40.0	Input kW, Thermal	4.76	5.55	7.50	8.78	11.3	13.2	17.9	21.1	23.4	27.6	30.5	36.0
		Output Torque Nm, Thermal	922	1112	1477	1781	2251	2715	3611	4355	4787	5774	6228	7511
		Input kW, Mechanical	4.64	5.03	7.84	8.52	11.1	12.1	12.8	13.9	18.5	20.3	24.3	26.7
		Output Torque Nm, Mechanical	899	1006	1543	1728	2222	2489	2562	2869	3779	4233	4959	5554
		Efficiency %	81.1	83.8	82.4	85.0	83.5	85.9	85.5	87.6	86.8	88.8	86.8	88.7
1000	33.3	Input kW, Thermal	4.19	4.88	6.54	7.64	9.78	11.4	15.4	18.1	20.1	23.6	26.1	30.7
		Output Torque Nm, Thermal	960	1158	1526	1840	2311	2787	3690	4451	4875	5880	6324	7626
		Input kW, Mechanical	4.16	4.50	7.02	7.62	10.1	10.9	11.5	12.6	16.7	18.3	21.8	23.8
		Output Torque Nm, Mechanical	955	1069	1638	1835	2379	2665	2744	3074	4047	4533	5277	5910
		Efficiency %	80.1	82.9	81.4	84.1	82.5	85.0	84.7	86.9	86.1	88.1	86.0	88.1
750	25.0	Input kW, Thermal	3.49	4.05	5.38	6.26	7.94	9.27	12.4	14.6	16.0	18.9	20.7	24.3
		Output Torque Nm, Thermal	1046	1262	1639	1977	2455	2961	3892	4695	5112	6167	6584	7942
		Input kW, Mechanical	3.48	3.76	5.87	6.35	8.30	9.00	9.46	10.3	13.8	15.0	18.3	20.0
		Output Torque Nm, Mechanical	1043	1168	1790	2005	2567	2875	2960	3315	4383	4908	5816	6514
		Efficiency %	78.5	81.4	79.8	82.6	80.9	83.6	83.3	85.7	84.7	87.0	84.7	86.9
500	16.7	Input kW, Thermal	2.82	3.26	4.26	4.94	6.19	7.19	9.54	11.1	12.2	14.3	15.6	18.2
		Output Torque Nm, Thermal	1229	1483	1891	2281	2786	3361	4376	5280	5700	6879	7252	8748
		Input kW, Mechanical	2.69	2.89	4.57	4.92	6.56	7.09	7.46	8.09	10.8	11.8	14.2	15.5
		Output Torque Nm, Mechanical	1172	1313	2029	2272	2957	3311	3414	3824	5041	5646	6618	7412
		Efficiency %	76.2	79.4	77.5	80.6	78.6	81.6	81.3	83.9	82.8	85.3	82.7	85.1
250	8.3	Input kW, Thermal	2.14	2.47	3.16	3.64	4.48	5.18	6.78	7.88	8.54	9.95	10.7	12.4
		Output Torque Nm, Thermal	1782	2151	2668	3220	3838	4631	5951	7183	7657	9243	9535	11508
		Input kW, Mechanical	1.67	1.62	2.84	3.04	4.09	4.38	4.62	4.98	6.65	6.46	8.82	9.52
		Output Torque Nm, Mechanical	1387	1407	2397	2685	3497	3917	4043	4528	5947	5990	7855	8797
		Efficiency %	72.4	75.9	73.7	77.1	74.7	78.0	77.7	80.8	79.4	82.2	79.1	82.0
Max Standard Shaft Torque Nm			1800	1800	3085	3085	4960	4960	8140	8140	8140	8140	7370*	7370*

Maximum torques stated apply for uniform load applications (starts / Hour < =5)

For applications with combinations of high torques, overhung loads, or number of starts, consult Renold

* WM 9 unit only: For torques higher than the stated maximum, two keyways and high tensile steel output shaft must be specified.

WM Series - Single Reduction - Selection Data

Mineral and Synthetic Oils

Nominal ratio: 35/1 Non Preferred Ratio

Input rpm	Output rpm	Gear Ratings	Centre Distance											
			4"		5"		6"		7"		8"		9"	
			Min	Syn	Min	Syn	Min	Syn	Min	Syn	Min	Syn	Min	Syn
1800	51.4	Input kW, Thermal	5.82	6.79	9.50	11.1	14.8	17.3	21.5	25.2	27.4	32.2	36.7	43.2
		Output Torque Nm, Thermal	878	1058	1462	1762	2309	2784	3389	4086	4371	5270	5784	6973
		Input kW, Mechanical	4.59	4.98	8.29	9.02	12.7	13.9	18.0	19.7	24.8	27.2	24.6	26.9
		Output Torque Nm, Mechanical	690	773	1273	1426	1990	2229	2840	3181	3957	4432	3854	4316
		Efficiency %	81.0	83.6	82.7	85.2	84.1	86.4	84.9	87.1	85.8	87.9	85.7	87.8
1500	42.9	Input kW, Thermal	5.01	5.84	8.12	9.49	12.5	14.7	18.2	21.3	23.2	27.2	31.1	36.5
		Output Torque Nm, Thermal	895	1079	1481	1785	2329	2808	3411	4113	4396	5300	5829	7027
		Input kW, Mechanical	4.13	4.47	7.39	8.03	11.4	12.4	16.1	17.6	22.2	24.2	22.0	24.0
		Output Torque Nm, Mechanical	736	824	1347	1508	2111	2364	3023	3386	4208	4713	4112	4605
		Efficiency %	79.9	82.7	81.8	84.3	83.2	85.6	84.1	86.4	85.1	87.2	85.1	87.2
1200	34.3	Input kW, Thermal	4.23	4.92	6.78	7.91	10.4	12.2	15.0	17.5	19.0	22.3	25.5	29.9
		Output Torque Nm, Thermal	928	1119	1522	1835	2377	2866	3465	4178	4454	5370	5903	7116
		Input kW, Mechanical	3.62	3.91	6.54	7.08	10.0	10.9	14.1	15.3	19.2	20.9	19.0	20.7
		Output Torque Nm, Mechanical	793	888	1466	1642	2291	2566	3251	3641	4486	5024	4391	4918
		Efficiency %	78.6	81.5	80.5	83.2	82.1	84.6	83.0	85.4	84.0	86.3	84.1	86.4
1000	28.6	Input kW, Thermal	3.73	4.32	5.92	6.89	9.01	10.5	12.9	15.1	16.3	19.1	21.8	25.6
		Output Torque Nm, Thermal	967	1166	1573	1897	2440	2943	3540	4269	4536	5470	5997	7231
		Input kW, Mechanical	3.24	3.49	5.80	6.27	8.96	9.72	12.7	13.8	17.4	19.0	17.1	18.6
		Output Torque Nm, Mechanical	840	941	1540	1725	2427	2718	3482	3900	4838	5418	4681	5242
		Efficiency %	77.5	80.6	79.5	82.3	81.0	83.7	82.0	84.5	83.0	85.5	83.2	85.6
750	21.4	Input kW, Thermal	3.11	3.60	4.88	5.66	7.34	8.54	10.4	12.1	13.1	15.3	17.4	20.3
		Output Torque Nm, Thermal	1053	1270	1691	2040	2595	3130	3731	4499	4751	5729	6243	7528
		Input kW, Mechanical	2.73	2.94	4.91	5.29	7.49	8.10	10.6	11.5	14.5	15.8	14.4	15.6
		Output Torque Nm, Mechanical	922	1033	1700	1904	2650	2968	3788	4242	5281	5915	5157	5775
		Efficiency %	75.8	79.0	77.7	80.8	79.3	82.2	80.3	83.1	81.4	84.1	81.7	84.3
500	14.3	Input kW, Thermal	2.52	2.90	3.88	4.48	5.74	6.65	8.04	9.33	9.99	11.6	13.1	15.3
		Output Torque Nm, Thermal	1238	1493	1953	2355	2951	3559	4185	5048	5280	6368	6863	8277
		Input kW, Mechanical	2.11	2.25	3.79	4.07	5.84	6.29	8.27	8.92	11.3	12.2	11.1	12.0
		Output Torque Nm, Mechanical	1032	1156	1906	2135	3003	3363	4308	4825	5991	6710	5823	6522
		Efficiency %	73.3	76.8	75.3	78.5	76.9	80.0	77.9	80.9	79.1	82.0	79.4	82.2
250	7.1	Input kW, Thermal	1.93	2.21	2.90	3.32	4.19	4.82	5.74	6.61	7.02	8.10	9.05	10.5
		Output Torque Nm, Thermal	1795	2166	2761	3332	4080	4922	5666	6835	7043	8497	8982	10835
		Input kW, Mechanical	1.31	1.39	2.36	2.52	3.65	3.90	5.17	5.54	7.08	7.59	6.98	7.49
		Output Torque Nm, Mechanical	1217	1363	2251	2521	3551	3977	5103	5715	7107	7960	6921	7751
		Efficiency %	69.3	73.1	71.2	74.9	72.9	76.4	73.8	77.2	75.1	78.4	75.2	78.5
Max Standard Shaft Torque Nm			1800	1800	3085	3085	4960	4960	8140	8140	8140	8140	7370*	7370*

Maximum torques stated apply for uniform load applications (starts / Hour < =5)

For applications with combinations of high torques, overhung loads, or number of starts, consult Renold

* WM 9 unit only: For torques higher than the stated maximum, two keyways and high tensile steel output shaft must be specified.

WM Series - Single Reduction - Selection Data

Mineral and Synthetic Oils

Nominal ratio: 40/1 Preferred Ratio

Input rpm	Output rpm	Gear Ratings	Centre Distance											
			4"		5"		6"		7"		8"		9"	
			Min	Syn	Min	Syn	Min	Syn	Min	Syn	Min	Syn	Min	Syn
1800	45.0	Input kW, Thermal	5.26	6.11	8.66	10.1	13.2	15.4	19.5	22.8	24.5	28.8	33.2	39.0
		Output Torque Nm, Thermal	883	1065	1493	1799	2307	2781	3450	4159	4390	5292	5972	7200
		Input kW, Mechanical	3.79	4.10	6.81	7.38	10.9	11.8	16.1	17.5	21.7	23.7	27.8	30.4
		Output Torque Nm, Mechanical	634	710	1169	1310	1899	2127	2846	3188	3879	4344	4992	5591
		Efficiency %	78.8	81.7	80.9	83.6	82.2	84.7	83.4	85.7	84.1	86.4	84.5	86.7
1500	37.5	Input kW, Thermal	4.53	5.26	7.41	8.63	11.2	13.1	16.5	19.3	20.8	24.3	28.1	33.0
		Output Torque Nm, Thermal	901	1086	1512	1823	2327	2805	3470	4183	4413	5321	6010	7245
		Input kW, Mechanical	3.45	3.72	6.13	6.64	9.71	10.5	14.3	15.6	19.3	21.1	24.8	27.1
		Output Torque Nm, Mechanical	683	765	1248	1398	2009	2250	3007	3367	4105	4597	5300	5936
		Efficiency %	77.7	80.7	79.9	82.7	81.2	83.8	82.5	84.9	83.3	85.7	83.8	86.1
1200	30.0	Input kW, Thermal	3.83	4.44	6.20	7.21	9.32	10.9	13.6	15.9	17.1	20.0	23.1	27.0
		Output Torque Nm, Thermal	934	1126	1554	1874	2374	2863	3524	4249	4471	5390	6079	7329
		Input kW, Mechanical	3.00	3.23	5.38	5.81	8.60	9.30	12.6	13.7	16.8	18.3	21.5	23.4
		Output Torque Nm, Mechanical	729	817	1346	1508	2187	2450	3264	3656	4405	4934	5660	6340
		Efficiency %	76.3	79.5	78.6	81.5	79.9	82.7	81.3	83.9	82.2	84.7	82.7	85.2
1000	25.0	Input kW, Thermal	3.38	3.90	5.42	6.29	8.09	9.40	11.8	13.7	14.7	17.1	19.8	23.1
		Output Torque Nm, Thermal	973	1174	1607	1937	2438	2939	3600	4341	4553	5489	6174	7444
		Input kW, Mechanical	2.69	2.89	4.76	5.14	7.66	8.27	11.3	12.3	15.2	16.5	19.4	21.1
		Output Torque Nm, Mechanical	773	866	1410	1579	2305	2582	3468	3884	4722	5289	6071	6799
		Efficiency %	75.2	78.4	77.5	80.5	78.8	81.7	80.2	82.9	81.1	83.8	81.7	84.3
750	18.8	Input kW, Thermal	2.83	3.26	4.48	5.18	6.61	7.65	9.50	11.0	11.8	13.7	15.8	18.4
		Output Torque Nm, Thermal	1060	1278	1728	2084	2592	3126	3795	4577	4769	5750	6427	7750
		Input kW, Mechanical	2.28	2.44	4.06	4.37	6.44	6.93	9.46	10.2	12.7	13.8	16.2	17.6
		Output Torque Nm, Mechanical	852	955	1566	1754	2525	2828	3777	4231	5145	5763	6618	7413
		Efficiency %	73.3	76.7	75.7	78.9	77.0	80.1	78.4	81.4	79.4	82.3	80.0	82.8
500	12.5	Input kW, Thermal	2.30	2.64	3.57	4.11	5.18	5.98	7.35	8.50	9.03	10.5	11.9	13.9
		Output Torque Nm, Thermal	1246	1503	1998	2410	2947	3554	4262	5140	5301	6393	7071	8527
		Input kW, Mechanical	1.75	1.87	3.11	3.33	5.00	5.35	7.37	7.91	9.89	10.6	12.6	13.6
		Output Torque Nm, Mechanical	947	1061	1738	1946	2839	3180	4268	4781	5809	6506	7465	8361
		Efficiency %	70.7	74.4	73.1	76.5	74.4	77.8	75.9	79.1	76.9	80.0	77.5	80.6
250	6.3	Input kW, Thermal	1.77	2.02	2.68	3.07	3.80	4.35	5.29	6.07	6.38	7.34	8.30	9.55
		Output Torque Nm, Thermal	1807	2180	2830	3415	4074	4915	5781	6973	7076	8535	9274	11187
		Input kW, Mechanical	1.10	1.16	1.96	2.08	3.15	3.35	4.64	4.95	6.24	6.66	7.97	8.52
		Output Torque Nm, Mechanical	1117	1252	2059	2306	3370	3774	5073	5682	6916	7746	8905	9974
		Efficiency %	66.5	70.5	68.9	72.7	70.1	73.8	71.5	75.2	72.6	76.1	73.1	76.6
Max Standard Shaft Torque Nm			1800	1800	3085	3085	4960	4960	8140	8140	8140	8140	7370*	7370*

Maximum torques stated apply for uniform load applications (starts / Hour < =5)

For applications with combinations of high torques, overhung loads, or number of starts, consult Renold

* WM 9 unit only: For torques higher than the stated maximum, two keyways and high tensile steel output shaft must be specified.

WM Series - Single Reduction - Selection Data

Mineral and Synthetic Oils

Nominal ratio: 45/1 Non Preferred Ratio

Input rpm	Output rpm	Gear Ratings	Centre Distance											
			4"		5"		6"		7"		8"		9"	
			Min	Syn	Min	Syn	Min	Syn	Min	Syn	Min	Syn	Min	Syn
1800	40.0	Input kW, Thermal	4.94	5.73	8.14	9.48	12.2	14.2	17.1	19.9	22.0	25.7	30.5	35.8
		Output Torque Nm, Thermal	919	1108	1555	1874	2346	2828	3308	3988	4330	5219	6080	7328
		Input kW, Mechanical	3.31	3.57	5.89	6.37	9.29	10.1	13.7	14.7	19.4	20.8	25.3	27.2
		Output Torque Nm, Mechanical	612	686	1119	1253	1788	2001	2653	2931	3806	4208	5026	5563
		Efficiency %	77.4	80.4	79.6	82.4	80.6	83.2	81.0	83.6	82.3	84.8	83.2	85.5
1500	33.3	Input kW, Thermal	4.27	4.94	6.97	8.10	10.3	12.0	14.5	16.9	18.7	21.8	25.9	30.3
		Output Torque Nm, Thermal	937	1130	1575	1899	2365	2852	3331	4016	4355	5250	6114	7370
		Input kW, Mechanical	3.00	3.23	5.32	5.75	8.30	8.98	12.2	13.2	17.2	18.7	22.5	24.5
		Output Torque Nm, Mechanical	655	734	1198	1341	1892	2119	2791	3126	4016	4498	5319	5957
		Efficiency %	76.3	79.4	78.6	81.5	79.5	82.3	80.0	82.8	81.4	84.0	82.4	84.8
1200	26.7	Input kW, Thermal	3.61	4.17	5.84	6.77	8.60	9.99	12.0	13.9	15.4	17.9	21.2	24.8
		Output Torque Nm, Thermal	973	1173	1619	1952	2414	2910	3385	4081	4413	5320	6181	7452
		Input kW, Mechanical	2.58	2.77	4.63	4.99	7.36	7.94	10.8	11.6	15.1	16.4	19.6	21.3
		Output Torque Nm, Mechanical	692	775	1279	1433	2060	2307	3037	3402	4337	4857	5712	6397
		Efficiency %	74.8	78.1	77.2	80.2	78.2	81.1	78.7	81.6	80.2	82.9	81.2	83.8
1000	22.2	Input kW, Thermal	3.19	3.68	5.11	5.91	7.48	8.66	10.4	12.0	13.2	15.4	18.2	21.2
		Output Torque Nm, Thermal	1014	1223	1675	2019	2479	2989	3458	4169	4495	5419	6277	7567
		Input kW, Mechanical	2.35	2.52	4.13	4.44	6.57	7.07	9.66	10.4	13.6	14.7	17.7	19.2
		Output Torque Nm, Mechanical	743	832	1350	1512	2173	2434	3217	3603	4620	5174	6109	6842
		Efficiency %	73.6	77.0	76.0	79.2	77.0	80.1	77.5	80.6	79.1	81.9	80.2	82.9
750	16.7	Input kW, Thermal	2.68	3.08	4.23	4.88	6.12	7.07	8.41	9.72	10.6	12.3	14.6	16.9
		Output Torque Nm, Thermal	1106	1334	1803	2174	2637	3179	3643	4392	4707	5675	6534	7878
		Input kW, Mechanical	1.98	2.11	3.51	3.76	5.52	5.93	8.10	8.70	11.4	12.2	14.8	16.0
		Output Torque Nm, Mechanical	813	911	1493	1672	2378	2663	3509	3930	5030	5634	6637	7434
		Efficiency %	71.7	75.3	74.2	77.5	75.1	78.4	75.6	78.8	77.2	80.3	78.4	81.3
500	11.1	Input kW, Thermal	2.19	2.50	3.39	3.89	4.82	5.54	6.53	7.51	8.17	9.43	11.1	12.8
		Output Torque Nm, Thermal	1302	1570	2087	2517	3000	3618	4084	4924	5230	6306	7192	8672
		Input kW, Mechanical	1.52	1.61	2.67	2.85	4.26	4.55	6.30	6.74	8.83	9.46	11.5	12.3
		Output Torque Nm, Mechanical	900	1008	1643	1840	2653	2971	3942	4415	5653	6331	7460	8356
		Efficiency %	69.1	72.9	71.5	75.1	72.4	75.9	72.8	76.3	74.4	77.8	75.7	78.9
250	5.6	Input kW, Thermal	1.69	1.92	2.55	2.91	3.55	4.05	4.71	5.38	5.81	6.64	7.72	8.86
		Output Torque Nm, Thermal	1894	2285	2963	3574	4154	5010	5522	6659	6972	8409	9442	11388
		Input kW, Mechanical	0.953	1.00	1.69	1.78	2.70	2.86	4.02	4.26	5.62	5.98	7.30	7.78
		Output Torque Nm, Mechanical	1063	1190	1951	2185	3156	3535	4702	5267	6751	7561	8923	9994
		Efficiency %	64.9	6.90	67.3	71.2	67.9	71.8	68.1	72.0	69.9	73.6	71.1	74.8
Max Standard Shaft Torque Nm			1800	1800	3085	3085	4960	4960	8140	8140	8140	8140	7370*	7370*

Maximum torques stated apply for uniform load applications (starts / Hour < =5)

For applications with combinations of high torques, overhung loads, or number of starts, consult Renold

* WM 9 unit only: For torques higher than the stated maximum, two keyways and high tensile steel output shaft must be specified.

WM Series - Single Reduction - Selection Data

Mineral and Synthetic Oils

Nominal ratio: 50/1 Preferred Ratio

Input rpm	Output rpm	Gear Ratings	Centre Distance											
			4"		5"		6"		7"		8"		9"	
			Min	Syn	Min	Syn	Min	Syn	Min	Syn	Min	Syn	Min	Syn
1800	36.0	Input kW, Thermal	4.67	5.41	7.44	8.63	11.3	13.1	16.4	19.1	20.4	23.8	27.9	32.5
		Output Torque Nm, Thermal	950	1145	1541	1858	2380	2869	3490	4206	4398	5301	6045	7286
		Input kW, Mechanical	2.93	3.10	5.11	5.45	8.09	8.64	12.0	12.7	17.0	17.9	22.9	24.2
		Output Torque Nm, Mechanical	591	649	1053	1164	1696	1875	2558	2781	3640	3964	4954	5405
		Efficiency %	76.0	79.1	77.6	80.6	79.0	81.8	80.1	82.8	80.9	83.5	81.5	84.1
1500	30.0	Input kW, Thermal	4.04	4.66	6.38	7.38	9.63	11.2	13.9	16.2	17.3	20.2	23.6	27.6
		Output Torque Nm, Thermal	969	1168	1561	1882	2399	2893	3509	4230	4422	5330	6080	7329
		Input kW, Mechanical	2.63	2.83	4.64	4.99	7.30	7.88	10.7	11.6	15.1	16.3	20.4	22.1
		Output Torque Nm, Mechanical	627	702	1129	1265	1812	2030	2700	3024	3837	4298	5235	5864
		Efficiency %	74.8	78.1	76.5	79.6	77.9	80.9	79.0	81.9	79.9	82.7	80.7	83.3
1200	24.0	Input kW, Thermal	3.43	3.95	5.35	6.18	8.02	9.28	11.5	13.3	14.3	16.6	19.4	22.6
		Output Torque Nm, Thermal	1006	1213	1605	1935	2449	2952	3564	4296	4479	5400	6149	7412
		Input kW, Mechanical	2.29	2.45	4.04	4.33	6.43	6.92	9.51	10.3	13.3	14.4	17.9	19.4
		Output Torque Nm, Mechanical	667	747	1205	1349	1957	2192	2939	3292	4166	4666	5657	6335
		Efficiency %	73.3	76.7	75.0	78.3	76.5	79.6	77.7	80.7	78.6	81.5	79.4	82.3
1000	20.0	Input kW, Thermal	3.03	3.48	4.69	5.41	6.98	8.06	9.95	11.5	12.3	14.3	16.7	19.4
		Output Torque Nm, Thermal	1050	1266	1660	2002	2515	3032	3641	4390	4562	5499	6244	7527
		Input kW, Mechanical	2.07	2.22	3.61	3.87	5.75	6.17	8.49	9.13	11.9	12.8	16.1	17.4
		Output Torque Nm, Mechanical	714	800	1272	1425	2067	2315	3099	3471	4406	4935	6020	6742
		Efficiency %	72.1	75.6	73.8	77.2	75.3	78.5	76.5	79.6	77.5	80.5	78.3	81.3
750	15.0	Input kW, Thermal	2.55	2.92	3.89	4.47	5.72	6.59	8.08	9.32	9.93	11.5	13.4	15.5
		Output Torque Nm, Thermal	1146	1381	1787	2155	2676	3226	3839	4628	4778	5760	6500	7836
		Input kW, Mechanical	1.74	1.85	3.06	3.27	4.84	5.18	7.12	7.64	10.0	10.8	13.5	14.5
		Output Torque Nm, Mechanical	776	869	1400	1568	2258	2529	3379	3785	4817	5395	6567	7355
		Efficiency %	70.2	73.9	71.9	75.4	73.3	76.8	74.5	77.8	75.5	78.8	76.4	79.6
500	10.0	Input kW, Thermal	2.09	2.38	3.13	3.57	4.52	5.17	6.29	7.22	7.65	8.79	10.2	11.7
		Output Torque Nm, Thermal	1351	1629	2069	2495	3047	3674	4312	5199	5310	6403	7152	8624
		Input kW, Mechanical	1.33	1.41	2.32	2.47	3.72	3.96	5.52	5.88	7.74	8.27	10.4	11.1
		Output Torque Nm, Mechanical	857	960	1533	1717	2504	2804	3776	4229	5372	6017	7310	8187
		Efficiency %	67.5	71.4	69.1	72.9	70.5	74.2	71.7	75.3	72.7	76.2	73.6	77.0
250	5.0	Input kW, Thermal	1.62	1.83	2.37	2.69	3.34	3.80	4.57	5.20	5.46	6.22	7.15	8.16
		Output Torque Nm, Thermal	1970	2376	2938	3543	4222	5092	5853	7058	7087	8546	9387	11320
		Input kW, Mechanical	0.837	0.879	1.48	1.56	2.37	2.50	3.53	3.73	4.96	5.25	6.68	7.08
		Output Torque Nm, Mechanical	1012	1133	1825	2044	2985	3343	4510	5051	6429	7200	8765	9816
		Efficiency %	63.3	67.5	64.7	68.8	65.9	70.0	67.0	71.0	67.9	71.8	68.7	72.6
Max Standard Shaft Torque Nm			1800	1800	3085	3085	4960	4960	8140	8140	8140	8140	7370*	7370*

Maximum torques stated apply for uniform load applications (starts / Hour < =5)

For applications with combinations of high torques, overhung loads, or number of starts, consult Renold

* WM 9 unit only: For torques higher than the stated maximum, two keyways and high tensile steel output shaft must be specified.

WM Series - Single Reduction - Selection Data

Mineral and Synthetic Oils

Nominal ratio: 60/1 Preferred Ratio

Input rpm	Output rpm	Gear Ratings	Centre Distance											
			4"		5"		6"		7"		8"		9"	
			Min	Syn	Min	Syn	Min	Syn	Min	Syn	Min	Syn	Min	Syn
1800	30.0	Input kW, Thermal	4.23	4.88	6.74	7.79	10.2	11.8	14.8	17.2	18.5	21.5	25.2	29.3
		Output Torque Nm, Thermal	999	1204	1627	1961	2509	3024	3685	4441	4652	5608	6398	7711
		Input kW, Mechanical	2.30	2.35	4.03	4.14	6.31	6.53	9.34	9.65	13.1	13.5	17.7	18.2
		Output Torque Nm, Mechanical	536	571	964	1029	1537	1653	2310	2475	3287	3496	4473	4766
		Efficiency %	73.2	76.4	75.1	78.2	76.5	79.5	77.7	80.6	78.6	81.4	79.4	82.1
1500	25.0	Input kW, Thermal	3.66	4.21	5.79	6.67	8.71	10.1	12.6	14.6	15.7	18.2	21.3	24.8
		Output Torque Nm, Thermal	1020	1229	1648	1986	2528	3047	3702	4462	4670	5629	6420	7739
		Input kW, Mechanical	2.05	2.18	3.63	3.83	5.74	6.07	8.44	8.98	11.8	12.6	15.8	17.0
		Output Torque Nm, Mechanical	563	629	1023	1129	1652	1821	2470	2734	3491	3882	4716	5268
		Efficiency %	72.0	75.4	73.9	77.2	75.4	78.6	76.6	79.7	77.6	80.6	78.4	81.3
1200	20.0	Input kW, Thermal	3.12	3.57	4.87	5.60	7.27	8.38	10.4	12.0	12.9	15.0	17.6	20.3
		Output Torque Nm, Thermal	1060	1278	1695	2044	2580	3111	3758	4529	4726	5697	6482	7814
		Input kW, Mechanical	1.81	1.92	3.17	3.38	5.00	5.36	7.39	7.93	10.4	11.2	14.0	15.1
		Output Torque Nm, Mechanical	608	680	1094	1225	1766	1978	2651	2969	3779	4232	5143	5760
		Efficiency %	70.5	74.1	72.3	75.8	73.9	77.3	75.2	78.4	76.2	79.3	77.1	80.1
1000	16.7	Input kW, Thermal	2.76	3.16	4.28	4.91	6.34	7.29	9.03	10.4	11.2	12.9	15.1	17.5
		Output Torque Nm, Thermal	1107	1334	1755	2115	2651	3196	3840	4629	4813	5801	6580	7931
		Input kW, Mechanical	1.63	1.73	2.84	3.03	4.48	4.79	6.61	7.08	9.22	9.89	12.5	13.4
		Output Torque Nm, Mechanical	645	722	1158	1297	1866	2090	2798	3134	3959	4434	5413	6063
		Efficiency %	69.2	72.9	71.1	74.7	72.6	76.1	73.9	77.3	75.0	78.2	75.9	79.0
750	12.5	Input kW, Thermal	2.34	2.66	3.56	4.07	5.22	5.98	7.35	8.44	9.03	10.4	12.1	14.0
		Output Torque Nm, Thermal	1210	1459	1892	2281	2825	3406	4052	4885	5044	6080	6851	8259
		Input kW, Mechanical	1.35	1.43	2.39	2.54	3.77	4.01	5.53	5.90	7.79	8.33	10.5	11.3
		Output Torque Nm, Mechanical	693	776	1260	1411	2032	2276	3037	3401	4343	4865	5938	6650
		Efficiency %	67.2	71.1	69.1	72.8	70.6	74.2	71.9	75.4	72.9	76.4	73.9	77.2
500	8.3	Input kW, Thermal	1.92	2.18	2.87	3.27	4.14	4.72	5.76	6.57	6.99	8.00	9.28	10.6
		Output Torque Nm, Thermal	1431	1725	2195	2646	3223	3887	4561	5499	5616	6771	7551	9104
		Input kW, Mechanical	1.03	1.09	1.81	1.91	2.88	3.05	4.28	4.54	6.02	6.41	8.11	8.64
		Output Torque Nm, Mechanical	764	855	1374	1539	2230	2498	3380	3785	4831	5411	6590	7381
		Efficiency %	64.5	68.6	66.2	70.2	67.7	71.6	68.9	72.7	70.0	73.7	70.9	74.5
250	4.2	Input kW, Thermal	1.50	1.69	2.20	2.48	3.09	3.49	4.21	4.77	5.03	5.71	6.57	7.47
		Output Torque Nm, Thermal	2095	2527	3129	3773	4486	5410	6216	7496	7524	9073	9950	11998
		Input kW, Mechanical	0.652	0.641	1.16	1.21	1.84	1.93	2.74	2.89	3.86	4.07	5.20	5.49
		Output Torque Nm, Mechanical	902	948	1636	1833	2662	2981	4032	4515	5760	6451	7853	8795
		Efficiency %	60.3	64.6	61.8	66.0	63.0	67.2	64.1	68.3	65.1	69.2	65.9	70.0
Max Standard Shaft Torque Nm			1800	1800	3085	3085	4960	4960	8140	8140	8140	8140	7370*	7370*

Maximum torques stated apply for uniform load applications (starts / Hour < =5)

For applications with combinations of high torques, overhung loads, or number of starts, consult Renold

* WM 9 unit only: For torques higher than the stated maximum, two keyways and high tensile steel output shaft must be specified.

WM Series - Single Reduction - Selection Data

Mineral and Synthetic Oils

Nominal ratio: 70/1 Preferred Ratio

Input rpm	Output rpm	Gear Ratings	Centre Distance											
			4"		5"		6"		7"		8"		9"	
			Min	Syn	Min	Syn	Min	Syn	Min	Syn	Min	Syn	Min	Syn
1800	25.7	Input kW, Thermal	3.61	4.13	5.73	6.57	8.64	9.94	12.5	14.4	15.5	17.9	21.1	24.4
		Output Torque Nm, Thermal	936	1129	1522	1835	2346	2828	3444	4150	4337	5227	5958	7180
		Input kW, Mechanical	1.92	1.90	3.34	3.32	5.22	5.23	7.64	7.66	10.8	10.8	14.5	14.6
		Output Torque Nm, Mechanical	489	508	877	913	1402	1468	2088	2184	2977	3110	4060	4238
		Efficiency %	68.6	72.1	70.6	74.0	72.3	75.6	73.6	76.8	74.6	77.7	75.4	78.4
1500	21.4	Input kW, Thermal	3.14	3.58	4.93	5.64	7.40	8.49	10.6	12.2	13.2	15.3	18.0	20.8
		Output Torque Nm, Thermal	955	1151	1542	1858	2366	2851	3465	4176	4364	5259	5998	7229
		Input kW, Mechanical	1.72	1.77	3.01	3.08	4.74	4.87	6.97	7.19	9.72	10.1	13.1	13.6
		Output Torque Nm, Mechanical	516	560	929	1001	1500	1619	2250	2430	3181	3439	4348	4694
		Efficiency %	67.3	71.0	69.3	72.9	71.1	74.5	72.4	75.8	73.5	76.8	74.4	77.6
1200	17.1	Input kW, Thermal	2.68	3.04	4.16	4.75	6.20	7.09	8.86	10.2	11.0	12.6	14.9	17.1
		Output Torque Nm, Thermal	991	1195	1585	1911	2414	2910	3519	4241	4422	5330	6069	7315
		Input kW, Mechanical	1.51	1.59	2.63	2.79	4.12	4.38	6.09	6.49	8.54	9.12	11.5	12.3
		Output Torque Nm, Mechanical	552	618	992	1111	1590	1781	2402	2691	3422	3833	4677	5238
		Efficiency %	65.6	69.6	67.7	71.5	69.4	73.1	70.8	74.4	71.9	75.5	72.9	76.3
1000	14.3	Input kW, Thermal	2.38	2.70	3.67	4.17	5.42	6.18	7.70	8.81	9.51	10.9	12.8	14.7
		Output Torque Nm, Thermal	1034	1246	1639	1976	2479	2988	3595	4333	4503	5428	6164	7430
		Input kW, Mechanical	1.36	1.44	2.36	2.50	3.73	3.96	5.50	5.84	7.67	8.17	10.3	11.0
		Output Torque Nm, Mechanical	585	656	1047	1172	1697	1901	2550	2856	3621	4055	4924	5515
		Efficiency %	64.2	68.3	66.3	70.2	68.0	71.8	69.4	73.1	70.6	74.2	71.6	75.1
750	10.7	Input kW, Thermal	2.02	2.28	3.07	3.47	4.48	5.08	6.30	7.17	7.72	8.81	10.3	11.8
		Output Torque Nm, Thermal	1128	1360	1764	2126	2637	3178	3789	4567	4716	5684	6416	7734
		Input kW, Mechanical	1.14	1.19	1.99	2.10	3.12	3.29	4.60	4.87	6.47	6.86	8.73	9.27
		Output Torque Nm, Mechanical	629	700	1136	1272	1827	2046	2751	3081	3938	4411	5395	6043
		Efficiency %	62.1	66.2	64.0	68.1	65.7	69.7	67.1	71.0	68.3	72.1	69.4	73.1
500	7.1	Input kW, Thermal	1.66	1.87	2.48	2.80	3.57	4.03	4.96	5.61	6.01	6.81	7.97	9.05
		Output Torque Nm, Thermal	1329	1602	2040	2459	3000	3617	4252	5126	5238	6314	7056	8506
		Input kW, Mechanical	0.879	0.853	1.53	1.60	2.43	2.56	3.61	3.80	5.05	5.32	6.78	7.16
		Output Torque Nm, Mechanical	694	723	1247	1397	2035	2280	3082	3451	4392	4919	5988	6707
		Efficiency %	59.1	63.4	60.9	65.2	62.5	66.7	63.9	68.0	65.1	69.1	66.1	70.1
250	3.6	Input kW, Thermal	1.31	1.46	1.91	2.14	2.69	3.01	3.66	4.10	4.36	4.90	5.69	6.40
		Output Torque Nm, Thermal	1936	2335	2892	3487	4153	5007	5764	6950	6980	8416	9248	11149
		Input kW, Mechanical	0.519	0.480	0.982	0.912	1.56	1.53	2.32	2.40	3.25	3.39	4.36	4.55
		Output Torque Nm, Mechanical	756	756	1474	1475	2404	2533	3638	4053	5182	5804	7062	7909
		Efficiency %	54.5	58.9	56.1	60.5	57.5	61.9	58.7	63.1	59.7	64.1	60.6	64.9
Max Standard Shaft Torque Nm			1800	1800	3085	3085	4960	4960	8140	8140	8140	8140	7370*	7370*

Maximum torques stated apply for uniform load applications (starts / Hour < =5)

For applications with combinations of high torques, overhung loads, or number of starts, consult Renold

* WM 9 unit only: For torques higher than the stated maximum, two keyways and high tensile steel output shaft must be specified.

WM Series - Single Reduction - Dimensions (mm)

TYPE WMSM - SHAFT MOUNTED

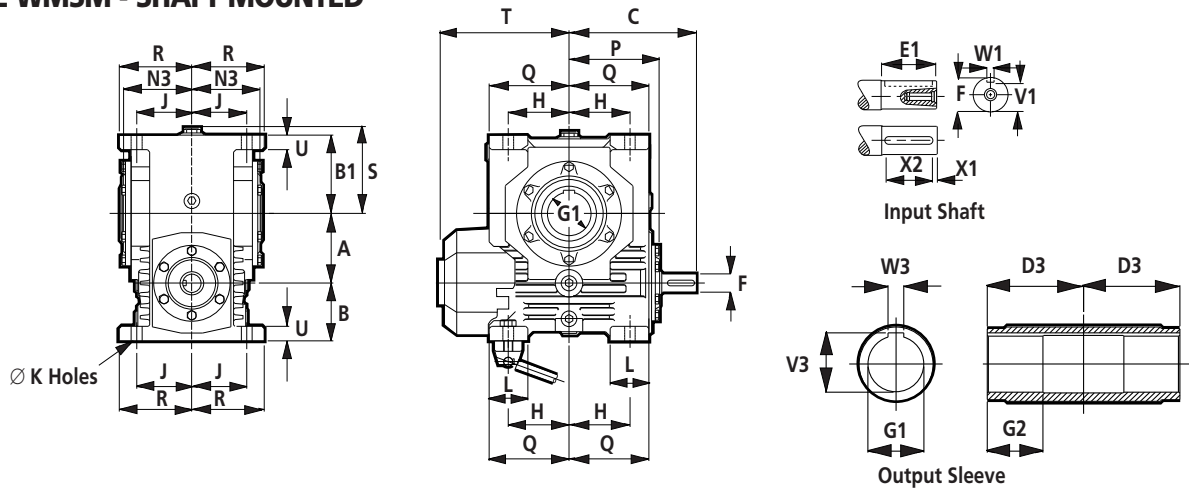

Size	Centre Distance		B	B1	C	H	J	K	L
	A	A							
	Ins								
4	4.00	101.6	108.0	120.7	229	108.0	101.6	22	65
5	5.00	127.0	114.3	146.1	260	123.8	111.1	22	75
6	6.00	152.4	127.0	171.5	279	133.4	120.7	22	85
7	7.00	177.8	146.1	196.9	318	152.4	133.4	22	95
8	8.00	203.2	146.1	222.3	343	171.5	133.4	26	100
9	9.00	228.6	158.8	247.7	387	193.7	149.2	26	110

Size	L3	N3	P	Q	R	S	T	U	Oil Capacity (approx) Litres*	Weight (approx) Kg
4	65	108	159	140	125	127	240	25	2.2/3.0	74
5	70	128	184	165	140	154	275	32	3.3/4.7	118
6	90	153	197	175	155	181	295	32	4.5/7.5	168
7	115	171	227	205	160	206	330	38	7.0/12.0	261
8	115	171	246	225	170	231	355	38	7.7/15.0	290
9	125	193	282	250	185	255	400	45	11.2/20.0	400

* - Min/Max dependant on mounting positions.

INPUT SHAFT

Size	E1	F	V1	W1	X1	X2	Tapped Hole
4	64	30k6	26.0	8P9	5	56	M10x22
5	76	38k6	33.0	10P9	5	63	M12X28
6	76	45k6	39.5	14P9	5	63	M16X36
7	89	45k6	39.5	14P9	5	80	M16X36
8	95	50k6	44.5	14P9	5	80	M16X36
9	102	55m6	49.0	16P9	5	90	M20X42

OUTPUT SLEEVE

Size	G1	G2	V3	W3	D3
4	60F7	65	64.4	18Js9	110
5	70F7	70	74.9	20Js9	130
6	90F7	90	95.4	25Js9	155
7	100F7	115	106.4	28Js9	174
8	100F7	115	106.4	28Js9	174
9	110F7	125	116.4	28Js9	202

WM Series - Single Reduction - Dimensions (mm)

TYPE WMU - UNDERDRIVEN

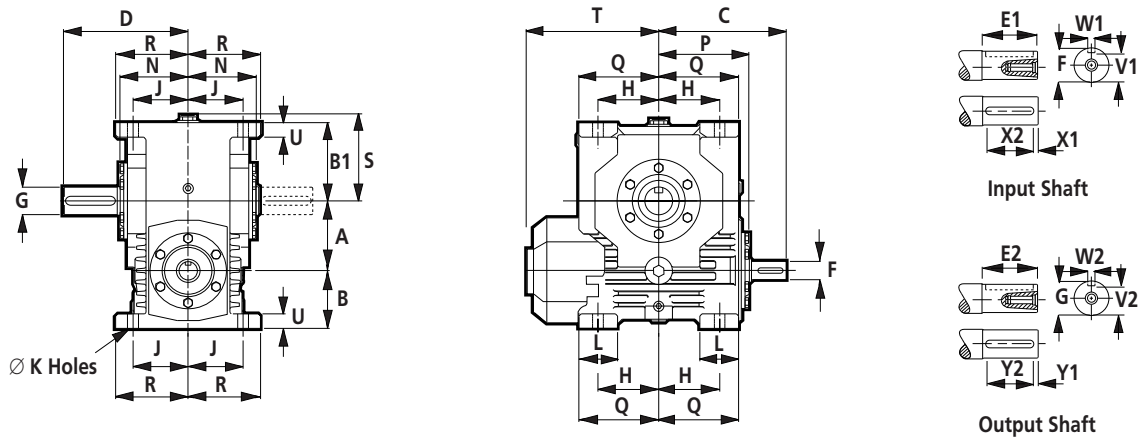

Unit Shown with Plug-in output shaft.

Size	Centre Distance		B	B1	C	D	H	J	K	L
	A	A								
	Ins									
4	4.00	101.6	108.0	120.7	229	230	108.0	101.6	22	65
5	5.00	127.0	114.3	146.1	260	280	123.8	111.1	22	75
6	6.00	152.4	127.0	171.5	279	305	133.4	120.7	22	85
7	7.00	177.8	146.1	196.9	318	355	152.4	133.4	22	95
8	8.00	203.2	146.1	222.3	343	355	171.5	133.4	26	100
9	9.00	228.6	158.8	247.7	387	343	193.7	149.2	26	110

Size	N	P	Q	R	S	T	U	Oil Capacity (approx) Litres*	Weight (approx) Kg
4	108	160	140	125	128	240	25	2.3	80
5	128	184	165	140	154	275	32	3.3	100
6	153	199	175	155	181	293	32	4.5	182
7	171	226	205	160	206	330	38	7.0	265
8	171	246	225	170	231	350	38	7.7	312
9	193	282	250	185	256	400	45	11.2	396

INPUT SHAFT

Size	E1	F	V1	W1	X1	X2	Tapped Hole
4	64	30k6	26	8P9	5	56	M10x22
5	76	38k6	33.0	10P9	5	63	M12X28
6	76	45k6	39.5	14P9	5	63	M16X36
7	89	45k6	39.5	14P9	5	80	M16X36
8	95	50k6	44.5	14P9	5	80	M16X36
9	102	55m6	49.0	16P9	5	90	M20X42

OUTPUT SHAFT

Size	E2	G	V2	W2	Y1	Y2	Tapped Hole
4	110	55m6	49.0	16P9	5	100	M20X42
5	140	65m6	58.0	18P9	5	125	M20X42
6	140	75m6	67.5	20P9	5	125	M20X42
7	170	85m6	76.0	22P9	5	160	M20X42
8	170	95m6	86.0	25P9	5	160	M24X60
9	146	85m6	76.0	22P9	5	140	M20X42

WM Series - Single Reduction - Dimensions (mm)

TYPE WMO - OVERDRIVEN

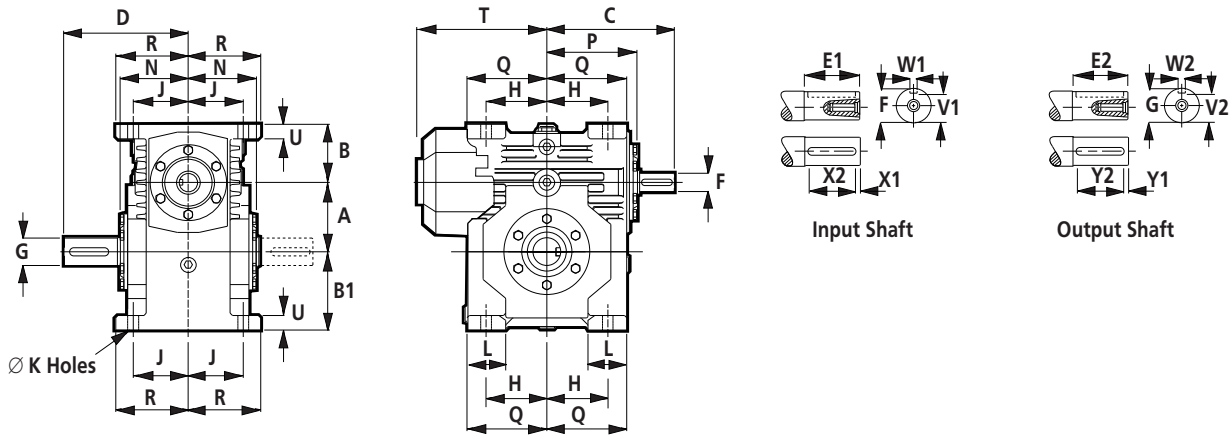

Unit Shown with Plug-in output shaft.

Size	Centre Distance		B	B1	C	D	H	J	K	L
	A	A								
	Ins									
4	4.00	101.6	108.0	120.7	229	230	108.0	101.6	22	65
5	5.00	127.0	114.3	146.1	260	280	123.8	111.1	22	75
6	6.00	152.4	127.0	171.5	279	305	133.4	120.7	22	85
7	7.00	177.8	146.1	196.9	318	355	152.4	133.4	22	95
8	8.00	203.2	146.1	222.3	343	355	171.5	133.4	26	100
9	9.00	228.6	158.8	247.7	387	343	193.7	149.2	26	110

Size	N	P	Q	R	T	U	Oil Capacity (approx) Litres*	Weight (approx) Kg
4	108	160	140	125	240	25	2.4	80
5	128	184	165	140	275	32	3.4	100
6	153	199	175	155	293	32	5.4	182
7	171	226	205	160	330	38	9.5	265
8	171	246	225	170	350	38	11.2	312
9	193	282	250	185	400	45	15.9	396

INPUT SHAFT

Size	E1	F	V1	W1	X1	X2	Tapped Hole
4	64	30k6	26	8P9	5	56	M10x22
5	76	38k6	33.0	10P9	5	63	M12X28
6	76	45k6	39.5	14P9	5	63	M16X36
7	89	45k6	39.5	14P9	5	80	M16X36
8	95	50k6	44.5	14P9	5	80	M16X36
9	102	55m6	49.0	16P9	5	90	M20X42

OUTPUT SHAFT

Size	E2	G	V2	W2	Y1	Y2	Tapped Hole
4	110	55m6	49.0	16P9	5	100	M20X42
5	140	65m6	58.0	18P9	5	125	M20X42
6	140	75m6	67.5	20P9	5	125	M20X42
7	170	85m6	76.0	22P9	5	160	M20X42
8	170	95m6	86.0	25P9	5	160	M24X60
9	146	85m6	76.0	22P9	5	140	M20X42

WM Series - Single Reduction - Dimensions (mm)

TYPE WMV - VERTICAL

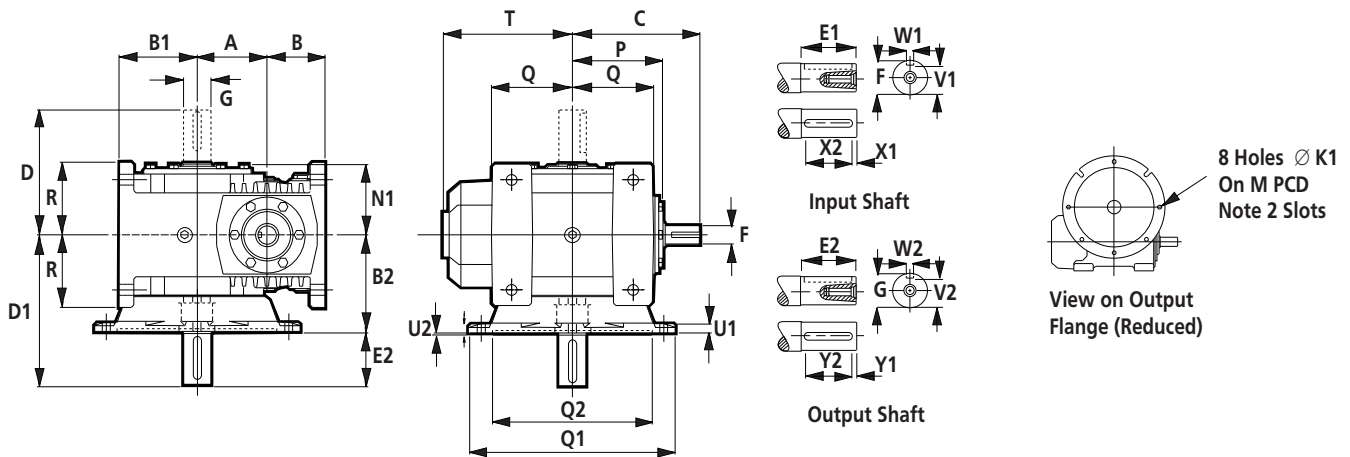

Unit Shown with plug-in output shaft.

Size	Centre Distance		B	B1	B2	C	D	D1	K1	M
	A	A								
	Ins									
4	4.00	101.6	108.0	120.7	183	229	230	293	17.5	300
5	5.00	127.0	114.3	146.1	197	260	280	337	17.5	350
6	6.00	152.4	127.0	171.5	215	279	305	355	17.5	400
7	7.00	177.8	146.1	196.9	248	318	355	418	17.5	500
8	8.00	203.2	146.1	222.3	248	343	355	418	17.5	500
9	9.00	228.6	158.8	247.7	285	387	343	431	22.0	600

Size	N1	P	Q	Q1	Q2	R	T	U1	U2	Oil Capacity (approx) Litres*	Weight (approx) Kg
4	108	160	140	350	250H8	125	240	19	6	2.7	94
5	128	184	165	400	300H8	140	275	19	6	4.7	116
6	153	199	175	450	350H8	155	293	19	6	7.1	202
7	171	226	205	550	450H8	160	330	24	6	11.0	300
8	171	246	225	550	450H8	170	350	24	6	14.3	350
9	193	282	250	660	550H8	185	400	25	6	20.4	447

INPUT SHAFT

Size	E1	F	V1	W1	X1	X2	Tapped Hole
4	64	30k6	26	8P9	5	56	M10x22
5	76	38k6	33.0	10P9	5	63	M12X28
6	76	45k6	39.5	14P9	5	63	M16X36
7	89	45k6	39.5	14P9	5	80	M16X36
8	95	50k6	44.5	14P9	5	80	M16X36
9	102	55m6	49.0	16P9	5	90	M20X42

OUTPUT SHAFT

Size	E2	G	V2	W2	Y1	Y2	Tapped Hole
4	110	55m6	49.0	16P9	5	100	M20X42
5	140	65m6	58.0	18P9	5	125	M20X42
6	140	75m6	67.5	20P9	5	125	M20X42
7	170	85m6	76.0	22P9	5	160	M20X42
8	170	95m6	86.0	25P9	5	160	M24X50
9	146	85m6	76.0	22P9	5	140	M20X42

WM Series - Single Reduction - Dimensions (mm)

TYPE WMA - AGITATOR

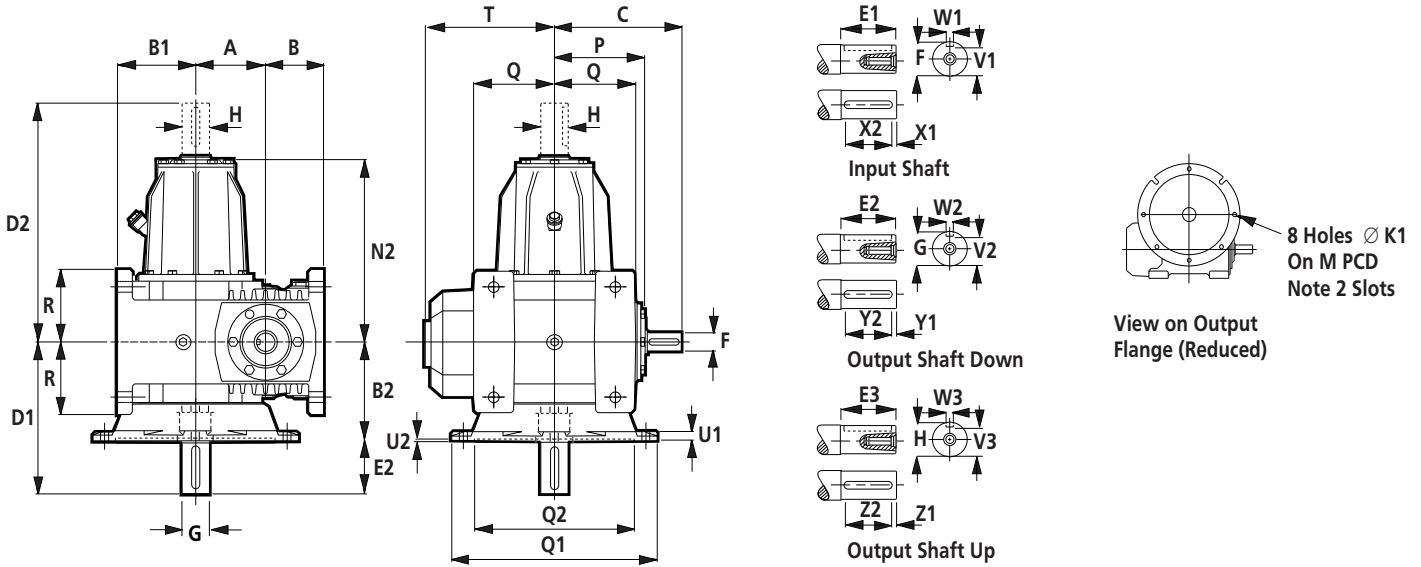

Unit Shown with solid output shaft.

Size	Centre Distance		B	B1	B2	C	D1	D2	K1	M
	A	A								
	Ins									
4	4.00	101.6	108.0	120.7	183	229	293	416	17.5	300
5	5.00	127.0	114.3	146.1	197	260	337	482	17.5	350
6	6.00	152.4	127.0	171.5	215	279	355	523	17.5	400
7	7.00	177.8	146.1	196.9	248	318	418	572	17.5	500
8	8.00	203.2	146.1	222.3	248	343	418	672	17.5	500
9	9.00	228.6	158.8	247.7	285	387	431	735	22.0	600

Size	N2	P	Q	Q1	Q2	R	T	U1	U2	Oil Capacity (approx) Litres*	Weight (approx) Kg
4	306	160	140	350	250H8	125	240	19	6	2.7	106
5	360	184	165	400	300H8	140	275	19	6	4.7	135
6	399	199	175	450	350H8	155	293	19	6	7.1	227
7	445	226	205	550	450H8	160	330	24	6	11.0	335
8	531	246	225	550	450H8	170	350	24	6	14.3	398
9	604	282	250	660	550H8	185	400	25	6	20.4	523

INPUT SHAFT

Size	E1	F	V1	W1	X1	X2	Tapped Hole
4	64	30k6	26.0	8P9	5	56	M10x22
5	76	38k6	33.0	10P9	5	63	M12X28
6	76	45k6	39.5	14P9	5	63	M16X36
7	89	45k6	39.5	14P9	5	80	M16X36
8	95	50k6	44.5	14P9	5	80	M16X36
9	102	55m6	49.0	16P9	5	90	M20X42

OUTPUT SHAFT DOWN

SIZE	E2	G	V2	W2	Y1	Y2	Tapped Hole
4	110	55m6	49.0	16P9	5	100	M20x42
5	140	65m6	58.0	18P9	5	125	M20X42
6	140	75m6	67.5	20P9	5	125	M20X42
7	170	85m6	76.0	22P9	5	160	M20X42
8	170	95m6	86.0	25P9	5	160	M24X50
9	146	85m6	76.0	22P9	5	140	M20X42

OUTPUT SHAFT UP

SIZE	E3	H	V3	W3	Z1	Z2	Tapped Hole
4	108	45k6	39.5	14P9	5	100	M16x36
5	115	55m6	49.0	16P9	5	100	M20X42
6	115	60m6	53.0	18P9	5	100	M20X42
7	120	75m6	67.5	20P9	5	110	M20X42
8	135	80m6	71.0	22P9	5	125	M20X42
9	146	85m6	76.0	22P9	5	140	M20X42

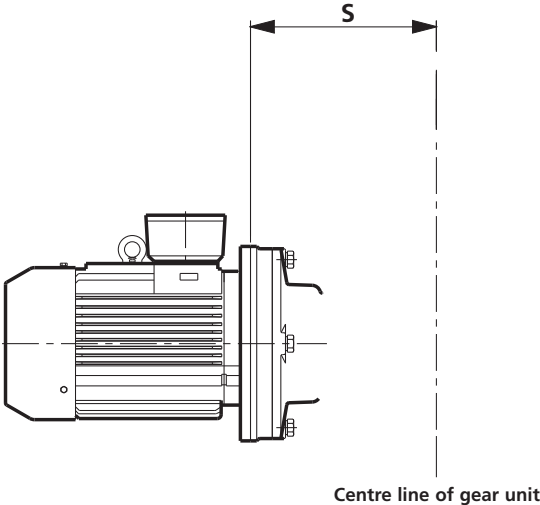
WM Series - Motorised Unit - Dimensions (mm)

UNIT REF	S								
	D80D	D90D	D100D	D112D	D132D	D160D	D180D	D200D	D225D
WM4	285	285	295	295	315	-	-	-	-
WM5	-	315	325	325	345	375	-	-	-
WM6	-	-	345	345	365	395	395	-	-
WM7	-	-	-	-	405	435	435	435	465
WM8	-	-	-	-	430	460	460	460	490
WM9	-	-	-	-	475	505	505	505	535

Motor dimensions please see page 11

WM Series - Output Shaft Shrink Disc

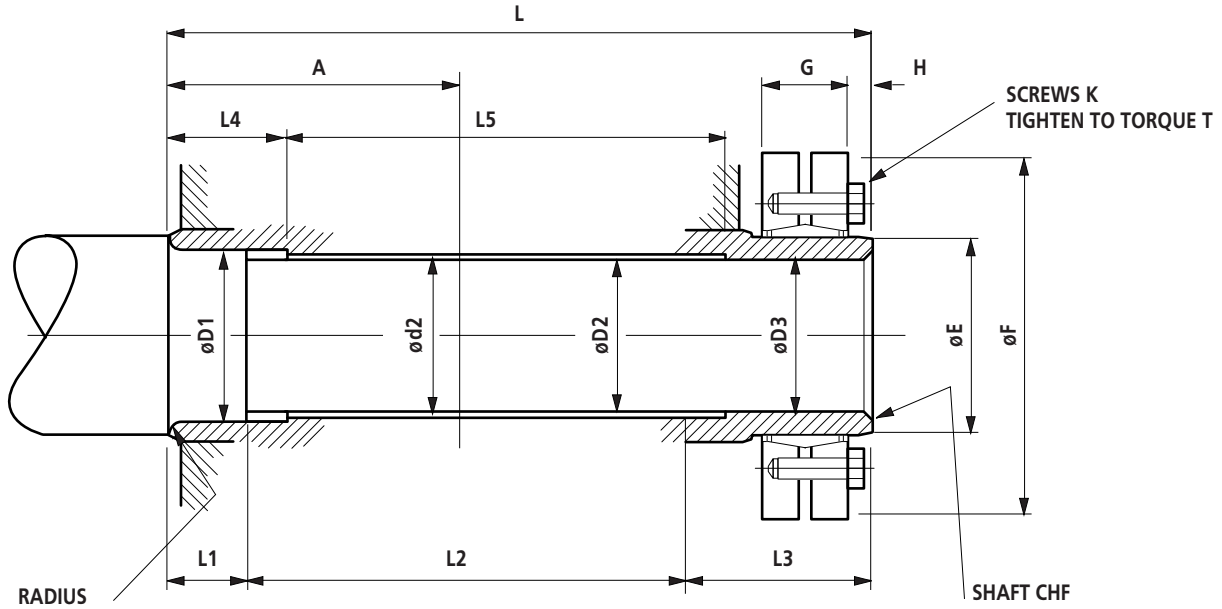

Gear Size	Driven Shaft								Hollow Shaft					Shrink Disc							Max S/Disc Torque
	D1	D2	D3	L1	L2	L3	Rad	Chf	A	d2	L	L4	L5	REF	ØE	ØF	G	H	K	T	
WM4	65	60	60	30	150	85	1.5	3	110	62	265	40	150	75-4071	75	138	32.5	9	M8	30	1600
WM5	75	70	70	35	180	95	1.5	3	130	72	310	50	180	90-4071	90	155	39	9	M8	30	3000
WM6	90	85	85	40	220	115	2	3	155	88	375	55	220	110-4071	110	185	50	12	M10	59	5400
WM7	100	95	95	45	250	135	2	3	174	98	430	60	250	125-4071	125	215	54	23	M10	59	7500
WM8	100	95	95	45	250	135	2	3	174	98	430	60	250	125-4071	125	215	54	23	M10	59	7500
														125-4091	125	215	65	12	M12	100	10000
WM9	110	105	105	50	275	170	2	3	202	108	495	65	275	140-4071	140	230	60.5	25.5	M12	100	10000
														140-4091	140	230	74	12	M12	100	13500

WM Series - Output Shaft - Dimensions (mm)

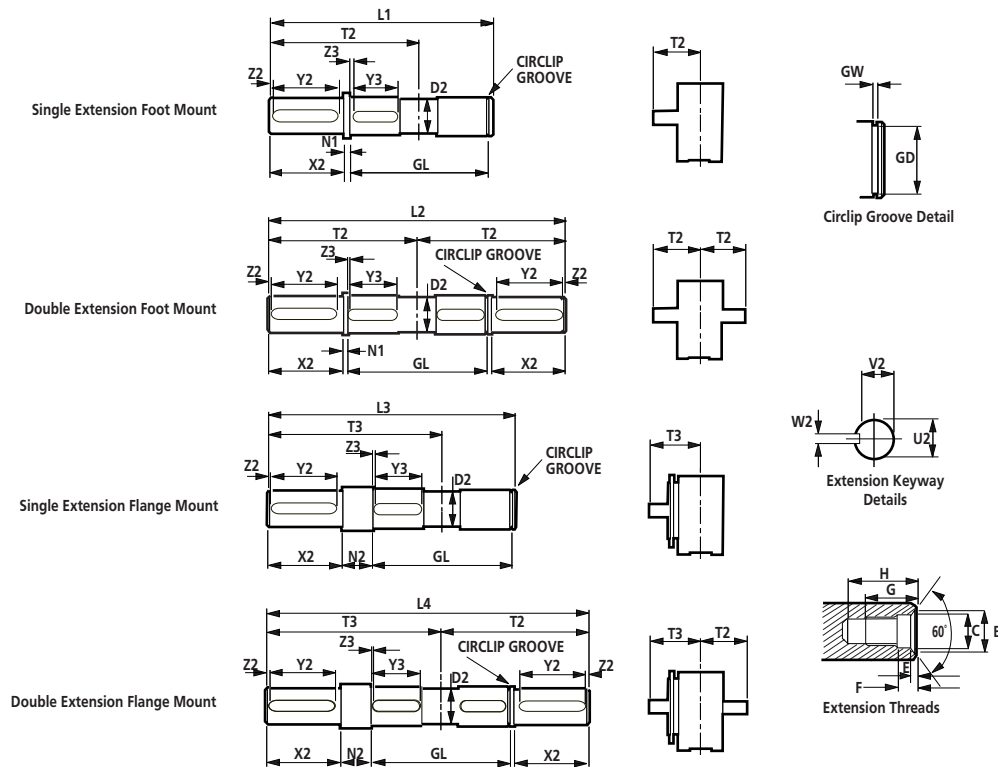

Unit Size	L1	L2	L3	L4	T2 T3	X2	Y2	Z2	GD	GW	GL	N1	N2	D2	Y3	Z3
WM4	347.5	460	410.5	523	230	110	100	5	57.00	2.29	222.15	10	73	56	70	3
					293				56.70	2.15	222.10					
WM5	418.5	560	475.5	617	280	140	125	5	67.00	2.79	262.65	10	67	66	90	2
					337				66.70	2.65	262.60					
WM6	469.5	610	519.5	660	305	140	125	5	86.50	3.33	313.15	10	60	86	110	3
					355				86.15	3.15	313.10					
WM7	538.5	710	601.5	773	355	170	160	5	96.50	3.33	351.15	11	74	96	125	3
					418				96.15	3.15	351.10					
WM8	538.5	710	601.5	773	355	170	160	5	96.50	3.33	351.15	11	74	96	125	3
					418				96.15	3.15	351.10					

WM9

THE WM9 UNIT HAS SOLID SHAFT ONLY

Unit Size	U2	V2	W2	B	C	E	F	G	H	Threads
WM4	55.030	49.0	15.982	28.4	21	6.4	15	42	53	M20X2.5-6H
	55.011	48.8	15.939							
WM5	65.030	58.0	17.982	28.4	21	6.4	15	42	53	M20X2.5-6H
	65.011	57.8	17.939							
WM6	75.030	67.5	19.978	28.4	21	6.4	15	42	53	M20X2.5-6H
	75.011	67.3	19.926							
WM7	85.035	76.0	21.978	28.4	21	6.4	15	42	53	M20X2.5-6H
	85.013	75.8	21.926							
WM8	95.035	86.0	24.978	34.2	25	8	18	50	63	M24X3.0-6H
	95.013	85.8	24.926							

WM Series - Torque Arm - Dimensions (mm)

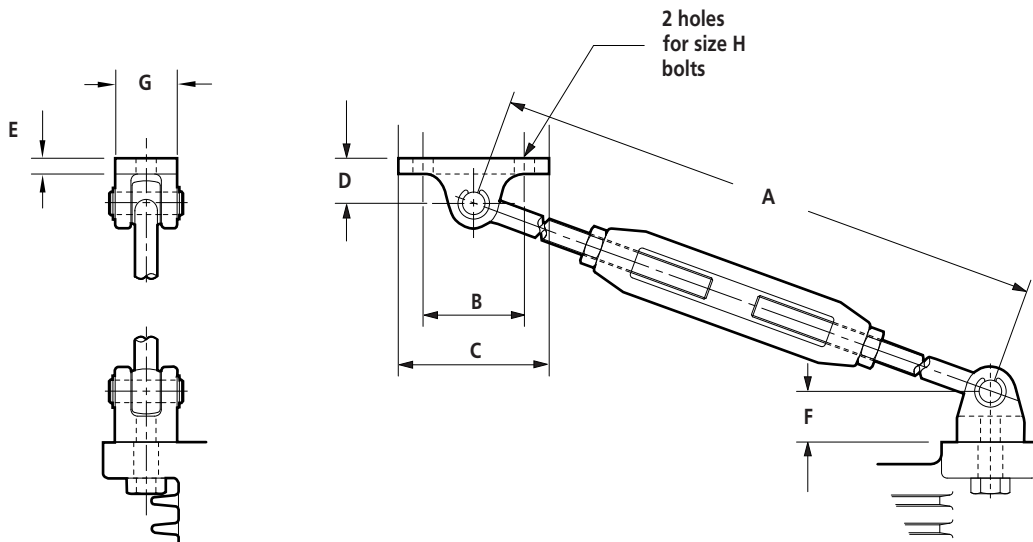

Unit Size	A	B	C	D	E	F	G	H
4	600	90	133	40	14	45	52	M16
	750							
5	600	90	133	40	14	45	52	M16
	750							
6	760	115	178	57	21	55	76	M20
	910							
7	760	115	178	57	21	55	76	M20
	910							
8	760	115	178	57	21	55	76	M20
	910							
9	760	140	210	70	25	70	100	M24
	910							

WM Series - Installation, Maintenance & Storage

Initial Running

All units are supplied without oil.

First Filling

When installed and before running, the unit should be filled with new lubricant to the correct level as follows.

With the gear stationary, remove the filler and breather plug and oil level plug. Fill until the lubricant level is visible at the indicator (if fitted) or until lubricant overflows from oil level aperture.

Replace and secure both plugs. Care should be taken to avoid overfilling, as this may cause subsequent leakage.

Starting Up

All units have been subjected to a short test before despatch to the customer but it takes many hours running under full load for the gear to attain its highest efficiency. The gear may if necessary be put to work immediately on full load, but if circumstances permit it is better for the ultimate life of the gear to run it in under gradually increasing load attaining the full load after about 20 to 40 hours. Reasonable precautions should however, be taken to avoid overloads in the early stage of running. Temperature rise on the initial run will be higher than that eventually attained after the gear is fully run in.

Routine Maintenance

The oil level in the unit should be regularly maintained, and should be checked at least once a month. To avoid false readings, examination of the oil level should be made with the gear stationary, and to maintain free ventilation of the unit under all conditions, the breather hole in the filler plug should be kept clear at all times.

Changing Oil

The oil should be changed completely at intervals depending upon the working conditions.

Grease Lubrication of Bearings

Where this feature is included, the bearing caps are fitted with a grease nipple or stauffer lubricator, which should be used to lubricate the bearings.

When mounted with wormshafts vertical, the top bearing requires grease lubrication. Standard units, therefore, need to be modified by the inclusion of a grease nipple and nylos ring adjacent to the top bearing. Customers must advise us of this requirement when placing enquiries and orders.

Couplings and Bedplates

All couplings should be carefully fitted and shafts accurately aligned. To prevent damage to the bearings, coupling half-bodies should not be hammered onto shafts.

Worm gear units and other drive components should be rigidly mounted on firm foundations to prevent movement and vibration which may affect the alignment of the shafts. Suitable bedplates can be supplied if required.

Abnormal Ambient Temperatures

If the gear unit is to be operated under extremes of temperature or humidity, special oils may be required and recommendations will be made on request.

Storage

All worm gear units stored or left inactive for long periods should be adequately protected, particularly those on exposed sites and those operating in corrosive atmospheres.

The following precautions will generally be adequate, but advice on the protection of particular units will be given, if required.

If empty of oil: spray the gear case interior with rust preventative oil; compatible with lubricant recommended for service conditions.

If filled with oil: operate at full speed once per month for not less than 10 minutes to ensure liberal coating of all internal parts with oil.

For indefinite storage: completely fill unit with oil ensuring complete submersion of all internal components and shafts should be occasionally turned by hand. When unit is returned to service, drain and refill with new oil to correct level.

External shaft extensions and oil seals can be protected by the use of grease impregnated tape. Full long term storage specification details can be obtained from Renold on request.

Spare Parts

Information relating to spare parts is available on request.

WM Series - Lubrication Information

Oil Lubrication

The correct fill of oil for the unit size and mounting position can be found in either the appropriate catalogue or the Installation and Maintenance Guide. Only good quality oils should be used, such as those listed below, as the use of inferior or unsuitable products may cause rapid wear and possible damage to the gearbox. Some EP additives such as Sulphur can attack Bronze especially at operating temperatures above 80° C and therefore should be avoided.

Oils with three viscosity ranges (Light, medium and heavy) are listed below, the correct choice depends on the application, operating speed, load and temperature. Temperature and speed can often be the main factor as it effects the operating viscosity. If the unit runs below the catalogue rating and operates at a temperature below 60° C then a light grade oil should be used. Operating at catalogue rating with temperatures up to 100° C require a medium grade, with higher temperatures and loading heavy grade oils should be used.

If the unit is operating with gear speeds below 2.5 m/s (500ft/min) then the next higher grade should be used. Using too heavy a grade than required will result in reduced efficiency, too light a grade will result in premature wear, if in doubt ask Renold Gears Technical Department

Which oil to select

There are three main oils Mineral, Synthetic (Polyalphaolefin) and Synthetic (Polyglycol). Mineral oils tend to be cheaper, have a lower life and are less efficient. Synthetic (Polyalphaolefin) can operate over a higher temperature range, are more efficient, give higher ratings and have a longer life and as such are preferred.

The use of Synthetic (Polyglycol) are not recommended without prior discussion with Renold as special paints and seals are required.

If necessary a list of recommended food grade oils is available on request.

Mineral Oil	Light		Medium		Heavy	
		Temp °C		Temp °C		Temp °C
Mobil Gear	630	-13 to 90	632	-13 to 90	634	-1 to 90
Mobil DTE	BB	-7 to 90	AA	2 to 90	HH	2 to 90
Castrol Alpha ZN	220	-9 to 120	320	-9 to 120	460	-9 to 120
Castrol AlphaMax	220	-24 to 80	320	-18 to 80	460	-15 to 80
Shell Vitrea	220	-24 to 120	320	-18 to 120	460	-15 to 120
Shell Omala	220	-9 to 80	320	-9 to 80	460	-9 to 80
Esso Teresso	220	-18 to 120	320	-12 to 120	460	-9 to 120
Esso Spartan EP	220	-30 to 80	320	-27 to 80	460	-18 to 80
Kluber Gem	220	-18 to 100	320	0 to 100	460	0 to 100

Synthetic (Polyalphaolefin)	Light		Medium		Heavy	
		Temp °C		Temp °C		Temp °C
Mobil Gear SHC	630	-42 to 160	632	-42 to 160	634	-39 to 160
Castrol Alpha T	220	-36 to 80	320	-33 to 80	460	-33 to 80
Shell Omala RL	220	-40 to 80	320	-40 to 80	460	-40 to 80
Esso Teresso SHP	220	-42 to 150	320	-36 to 150	460	-30 to 150

Notes

ARGENTINA

Bennett Anderson,
Gonzales Y Cia SA, J.Aguero 1817
(1605) Munro
Buenos Aires
Tel: + 54 11 4761 5007/ 3531
Fax: + 54 11 4760 0866

Los Ases Ketten SA,
Avda Gaona 4046,
1407 Buenos Aires
Tel: + 54 116710855
Fax: + 54 116713141

AUSTRALIA

Renold Australia Proprietary Ltd
508-520 Wellington Road,
Mulgrave, Victoria 3170, Mulgrave
North
Tel: +61 (0) 3 9262 3333
Fax: +61 (0) 3 9561 8561
Branch Tel: +61 (0) 3 9262 3355
Email: melcag@renold.com.au

Unit 1,
12-18 Victoria Street, Lidcombe,
Sydney, NSW 2141.
Tel: +61 (0) 2 9649 3122
Fax: +61 (0) 2 9646 1295
Email: nswsales@renold.com.au

Unit 10,
31 Boyland Avenue,
Coopers Plains, Brisbane,
Queensland 4108.
Tel: +61 (0) 7 3275 2155
Fax: +61 (0) 7 3875 1779

Corner Ormond & George Sts.
Hindmarsh, Adelaide,
South Australia 5007.
Tel: +61 (0) 8 8346 9077
Fax: +61 (0) 8 8340 1217

Unit 2,
127 Grandstand Street, Belmont,
Perth, West Australia 6104.
Tel: +61 (0) 8 9479 1388
Fax: +61 (0) 8 9479 1364

Unit 13
56 Industrial Drive,
Mayfield, NSW 2304
Tel: +61 (0) 2 4960 8440
Fax: +61 (0) 2 4960 8455

PO Box 159,
Unanderra, Wollongong, NSW 2526.
Tel: +61 (0) 2 42 621771
Fax: +61 (0) 2 42 621772

Shop B,
247 Ingham Road,
Garbutt, Townsville, QLD 4814.
Tel: +61 (0) 7 4779 5922
Fax: +61 (0) 7 4775 1446

AUSTRIA

Renold GmbH (Lageplan)
Rudolf Hausner Gasse 6
1220 Wien
Austria.
Tel: +43 (0) 1 3303484 0
Fax: +43 (0) 1 3303484 5
Email: office@renold.at

BANGLADESH

Brady & Co (Bangladesh) Ltd,
31, Bangabandhu Avenue,
Dhaka-1000
Tel: + 880 2802358
Fax: + 880 2802358

BELGIUM

Renold Continental Ltd
Allée Verte 1,1000 Brussel.
Tel: +32 (0) 2 2011262
Fax: +32 (0) 2 2032210
Email: info@renold.be

CANADA

Renold Canada Ltd
121 Roy Boulevard, Brantford,
Ontario, N3T 5N4
Toll Free: 1-800-265-9970
Tel: +1 519 756 6118
Fax: +1 519 756 1767
Email: inquiry@renoldcanada.com

622 rue De Hull,
Ville La Salle,
Quebec, H8R 1V9.
Toll Free: 1-800-361-1414
Tel: +1 514 367 1764
Fax: +1 514 367 4993

CHILE

Sargent S.A.,
Avda. Presidente Bulnes No 205,
Casilla 166-D,
Santiago - Chile.
Tel: (56 2) 510 3000
Fax: (56 2) 698 3989
Email: secventas@sargentagricola.cl

CHINA

Nanzheng Office
Unit A4215,
No.580 Nanjing West Road,
Nanzheng Building Jing An District
Shanghai
200041
China
Tel: +86 21 5046 2696
Fax: +86 21 5046 2695
Email: sales@renold.cn

COLOMBIA

Transmission de Potencia SA
Carrera 68B No10 - 98
Apartado Aereo 6794
Santafe de Bogato DC
Tel: + 571 2600100
Fax: + 571 2904823

Importadora Casa Sueca Ltda.,
Calle 52, No. 1N-74,
Apartado Aereo 1208, Cali.
Tel: 00 57 2346 4455
Fax: 00 57 2346 4967

CZECH REPUBLIC

Renold GesmbH
Technical Office, Dipl. Ing. R.
Badura,
Jaroslavice 129, CZ-76001 Zlin.
Tel: +42 67 7211074
Fax: +42 67 7211074

DENMARK

Renold A/S,
Skelmarksvej 6, Postboks 90,
2605 Brøndby.
Tel: +45 43 452611
Fax: +45 43 456592
Email: infor@renold.com

EGYPT

Itaco,
Int'l for Trading & Agency,
P.O. Box 7550, Nasr City, Cairo.
Tel: + 20 2 2718036
Fax: + 20 2 2878089

EL SALVADOR

MVA & Cia
Residencial San Luis,
Avenida 4 #45 Block 2,
San Salvador,
El-Salvador, Central America
Tel: + 503 274 649

FINLAND

Kraftmek Oy,
Hitsaajankatu 9, P.O. Box 36,
FIN-00811 Helsinki
Tel: + 358 9 7557355
Fax: + 358 9 7550414

FRANCE

Brampton Renold,
Zone Industrielle A, Rue de la
Pointe, BP 359, 59473 Seclin Cedex.
Tel: +33 (0) 320 16 29 29
Fax: +33 (0) 320 16 29 00

GERMANY

RENOLD Getriebe + Kupplungen
Niederlassung Deutschland
Veynastrasse 9 , D - 53894
Mechernich
Tel : +49 2256 - 959074
Fax : +49 2256 - 959169
Email: renold.deutschland
@renold.com

GREECE

Provatias Engineering
53/47 Dragatsaniou St,
185 - 45 Piraeus.
Tel: + 30 1 4170266
Fax + 30 1 4170253
Email : renold.
deutschland@renold.com

HOLLAND

Renold Continental Ltd,
Jarmuiden 30c,
1046 AD Amsterdam.
Tel: +31 (0) 20 614 6661
Fax: +31 (0) 20 614 6391
Email: info@renold.nl

HUNGARY

Renold GesmbH
Technical Office, Ing. Havasi Janos,
Ret Utca 25, H-6200 Kiskörös.
Tel: +36 (0) 78 312483
Fax: +36 (0) 78 312484

INDIA

Volts Limited.,
Machine Tool Division,
Volts House B, 3rd Floor,
TB Kadam Marg,
Chinchpokli,
Mumbai 400033
Tel: 091 22 370 0829
Fax: 091 22 371 4889
Email: mshaik@voltsltd.com

NORTHERN IRELAND

Henry R. Aytton Ltd,
Derrriagh, Dunmurry, Belfast.
Tel: 01232 618511
Fax: 01232 602436

IRELAND

E. Fox
Adelaide House
Baldonnell Business Park
Dublin 22
Tel + 353 (0) 1 4693500
Fax + 353 (0) 1 4693555

ISRAEL

Technica J. Bokstein Co. Ltd,
3 Hatrupa Street,
Netanya 42504
Tel: + 972 9 8850505
Fax: + 972 36131074

ITALY

Bianchi Cuscinetti SpA
Via Zuretti, 102, 20125 Milano,
Tel: + 39 02 67861
Fax: + 39 02 66981669

JAMAICA

Mastertron Ltd,
21-25 Hanover Street, P.O. Box 73
Kingston.
Tel: + 18 767 540557
Fax: + 18 769 227807

KOREA

S.S. Corporation,
Yeouido, P.O. Box 60, Seoul.
Tel: 00-822-783-6829
Fax: 00-822-784-9322
Email: sslcorp@chollian.net

MALAYSIA

Renold (Malaysia)
LOT 2, Jalan Kecapi 33/2,
Eithe Industrial Park,
Off Jalan Bukit, Kemuning,
40400 Shah Alam, Selangor,
Malaysia.
Tel: + 60 3 5122 9880
Fax: + 60 3 5191 9881
Email: malaysia@renold.com

201, Jalan Simbang,
Taman Perling,
81200 Joho Bharu, Johor, Malaysia.
Tel: + 60 (0) 7 2384152-3
Fax: + 60 (0) 7 2384155
Email: malaysia@renold.com

67A, Jalan Medan Ipoh 6,
Bandar Baru Medan,
31400 Ipoh, Perak
Tel: + 60 (0) 5 548 0059
Fax: + 60 (0) 5 548 0214
Email: malaysia@renold.com

28B Jalan Perai Jaya 3,
Bandar Perai Jaya, 13600 Perai,
Penang, Malaysia
Tel: + 604-399 9648
Tel: + 604-399 0648
Fax: + 604-399 5649
Email: malaysia@renold.com

MAURITIUS

Dynamotors Ltd,
P.O. Box 733, Bell Village,
Tel: + 230 2122847/8/9
Fax: + 230 2088348

MEXICO

Accesorios Automotrices y
Rodamientos Industriales,
S.A. de C.V., Calz Legaria 833-A
Col Irigacion, Mexico DF 11500
Tel: + 52 5 395 6300
Fax: + 52 5 395 6370

RENOLD Worldwide Sales and Services**NEW ZEALAND**

Renold New Zealand,
594 Rosebank Road,
Avondale, Auckland.

Postal Address:
PO Box 19460,
Avondale, Auckland.
Tel: + 64 (0) 9 828 5018
Fax: + 64 (0) 9 828 5019
Email: aksales@renold.co.nz

Christchurch Branch Office,
32 Birmingham Drive, Christchurch,
PO Box 9006, Christchurch,
Tel: + 64 03 338 2169
Fax: + 64 03 338 8663

NORWAY

G. Heier A/S,
Postal Address: Postboks 6615,
Rodelokka, 0502 Oslo, Norway.
Office Address: Thv, Meyersgt.
7, Oslo.
Tel: + 47 232 34230
Fax: + 47 232 34242

PAKISTAN

Brady & Co. of Pakistan Ltd,
Shernaz House, P.O. Box 4453,
West Wharf Road, Karachi 2.
Tel: + 92 21.2310367/201712
Fax: + 92 21.2313376/2313378

PERU

Corporacion Basco S.A.C.
Av. Argentina 1165,
Lima 1, RUC 25776186.
Tel: + 51 1 4336633
Fax: + 51 1 4313188

PORTUGAL

Harker, Sumner, S.A.
Zona Industrial Maia 1 - Sector X
4475 - 132 Gemunde - Maia
Portugal.
Tel: + 351 229 4478 090
Fax: + 351 229 4478 098
E-mail: accionamantos.ind@harker.pt

SINGAPORE

Renold Transmission Limited
63 Hillview Avenue, #07-13,
Lam Soon Industrial Building,
Singapore 669569.
Tel: + 65 6760 2422
Fax: + 65 6760 1507
E-mail: renold@mbox5.singnet.com.sg

SOUTH AFRICA

Renold Croft (Pty) Limited,
Corner Liverpool and Bolton Streets,
Nestadt Industrial Sites, Benoni, 1501
Postal Address: Private Bag x 030,
Benoni, 1500.
Tel: + 27 (0) 11 747 9500
Fax: + 27 (0) 11 747 9505
E-mail: renold@iafrica.com

P.O. Box 2661, Witbank 1035,
Mpumalanga,
Republic of South Africa.
Tel: +27 (0) 13 692 7760
Fax: +27 (0) 13 697 0546
Email: renoldwit@worldonline.co.za

SPAIN

Renold Spain
Antoni Gaudí, 21
E-08850 Gavá (Barcelona)
Barcelona, Spain
Tel: + 34 93 638 05 58
Fax: + 34 93 638 05 58
E-mail: renold@renold_hitec.com

SWEDEN

Renold A/S
Skelmarksvej 6, Postboks 90
2605 Brøndby
Denmark.
Tel: + 45 43 452611
Fax: + 45 43 456592
E-mail: infor@renold.com

SWITZERLAND

Renold (Switzerland) Gmbh,
Ringstrasse 16, Postfach 1115
CH-8600 Dübendorf 1.
Tel: + 41 (0) 44 824 8484
Fax: + 41 (0) 44 824 8411
E-mail: dubendorf@renold.com

Route De Prilly 25,
CH-1023 Crissier.
Tel: + 41 (0) 21 632 9460
Fax: + 41 (0) 21 632 9475
E-mail: crissier@renold.com

THAILAND

United Power Engineering Co Ltd
4 Soi Sukhumvit 81 (Siripot)
Sukhumvit Road
Bangjak, Phrakhanong
Bangkok 10260.
Tel: + 66 2 7425366
Fax: + 66 2 7425379

TRINIDAD

Tracmac Engineering Ltd,
P.O. Box 945, Port of Spain,
Trinidad, West Indies.
Tel: + 1 665 460 1532
Fax: + 1 868 671 0012

TURKEY

Glengo Ithalat Ihracat Mumessillik
AS,
Gungoren Cad. No. 35 Bagcilar,
34560
Bakirkoy, Istanbul.
Tel: + 90 212 4613970
Fax: + 90 212 4613972
www.glengo.com.tr

UNITED KINGDOM

Renold Gears
Holroyd Gears Works, Milnrow,
Rochdale OL16 3LS
Tel: +44 (0) 1706 751000
Fax: +44 (0) 1706 751001
E-mail: gears.sales@renold.com
Web: www.renold.com

Renold Clutches & Couplings

Wentloog Corporate Park,
Newlands Road,
Cardiff CF3 2EU, Wales
Tel: + 44 (0) 29 20792737
Fax: + 44 (0) 29 20793004
(Sales):+ 44 (0) 29 20791360
E-mail: couplings@cc.renold.com
Web: www.renold.com

Renold Hi-Tec Couplings

112 Parkinson Road
Halifax HX1 3QH
Tel: +44 (0) 1422 255000
Fax: +44 (0) 1422 320273
E-mail: sales@hitec.renold.com
Web: www.renold.com

Renold Chain

UK NSC
The Derby Turn Building
Derby Road
Burton upon Trent
Staffordshire DE14 1RS
Tel: +44 (0) 1283 512 940
Fax: +44 (0) 1283 512 628
E-mail: enquiry@renold.com

USA

Renold Inc
Bourne Street, PO Box A, Westfield,
New York, 14787-9706
Tel: + 1 716 326 3121
Fax: + 1 716 326 6121
E-mail: ainfo@renoldajax.com

VENEZUELA

Equipos Y Accesorios Astral CA,
Apartado 1651 Valencia.
Tel: + 584 1 332042
Fax: + 584 1 345641

WEB

www.renold.com

Terms and Conditions

- In the interests of safety, customers are reminded that when purchasing any technical product for use at work (or otherwise), any additional or up-to-date information and guidance, which it has not been possible to include in the publication, should be obtained by you from your local sales office in relation to the suitability and the safe and proper use of the product. All relevant information and guidance must be passed on by you to the person engaged in, or likely to be affected by or responsible for the use of the product
- The performance levels and tolerances of our product stated in this catalogue (including without limitation, serviceability, wearlife, resistance to fatigue, corrosion protection) have been verified in a programme of testing and quality control in accordance with Renold, independent and/or international standard recommendations. No representations or warranties are given that our product shall meet the stated performance levels or tolerances for any given application outside the performance levels and tolerances for the product's own specific application and environment.

- Whilst all reasonable care in compiling the information contained in this catalogue is taken, no responsibility is accepted for errors.
- All information contained in this catalogue is subject to change without notice.
- The illustrations used in this catalogue represent the type of product described but the goods supplied may vary in some detail from those illustrated.
- The right is reserved to make modifications to the product to meet manufacturing conditions and/or developments (for example in design or materials).
- Product can be supplied by Renold companies or representatives around the world on the standard terms and conditions of sale of the company or representative from which the product is purchased.
- Copyright Renold Power Transmission Limited 2001. All rights reserved.

Nothing contained in this publication shall constitute a part of any contract, express or implied.

AUSTRALIA

Melbourne (Victoria)
Tel + 61 (03) 9262 3333
Fax + 61 (03) 9561 8561
also at: Sydney, Brisbane, Adelaide, Perth,
Newcastle, Wollongong, Townsville.

AUSTRIA

Vienna
Tel + 43 (0) 13303484-0
Fax + 43 (0) 13303484-5
also at: Kiskörös (Hungary), Jaroslavice
(Czech Republic).

BELGIUM

Brussels
Tel + 32 (0) 2 201 1262
Fax + 32 (0) 2 203 2210

CANADA

Brantford (Ontario)
Tel + 1 519 756 6118
Fax + 1 519 756 1767
also at: Montreal.

CHINA

Shanghai
Tel + 21 5046 2696
Fax + 21 5046 2695

DENMARK

Brøndby (Copenhagen)
Tel + 45 43 45 26 11
Fax + 45 43 45 65 92

FRANCE

Seclin
Tel + 33 (0) 320 16 29 29
Fax + 33 (0) 320 16 29 00

GERMANY

Mechernich
Tel : + 49 2256 - 959074
Fax : + 49 2256 - 959169

KOREA

Seoul
Tel + 822 783 6829
Fax +822 784 9322

MALAYSIA

Selangor Darul Ehsan
Tel + 60 3-5191 9880
Fax + 60 3-5191 9881
also at: Johor Bharu, Ipoh, Penang.

NETHERLANDS

Amsterdam
Tel + 31 206 146661
Fax + 31 206 146391

NEW ZEALAND

Auckland
Tel + 64 9 828 5018
Fax + 64 9 828 5019
also at: Christchurch.

SINGAPORE

Singapore
Tel + 65 6760 2422
Fax + 65 6760 1507

SOUTH AFRICA

Benoni
Tel + 27 11 747 9500
Fax + 27 11 747 9505
also at: Witbank.

SPAIN

Barcelona
Tel + 34 93 638 05 58
Fax + 34 93 638 05 58

SWEDEN

Brøndby (Copenhagen)
Tel + 45 43 45 26 11
Fax + 45 43 45 65 92

SWITZERLAND

Dübendorf (Zürich)
Tel + 41 (0) 44 824 84 84
Fax + 41 (0) 44 824 84 11
also at: Crissier (Lausanne).

UK

Renold Gears, Rochdale
Tel + 44 (0) 1706 751000
Fax + 44 (0) 1706 751001
e-mail : gears.sales@renold.com

USA

Westfield NY
Tel + 1 716 326 3121
Fax + 1 716 326 6121

WEB

www.renold.com

E-MAIL

e-mail : gears.sales@renold.com

For other country distributors
please contact Renold UK.

CAT WM/06.08

RENOLD
Superior Gear Technology

www.renold.com